

# SHORT WAVE RADIO

November  
1933

W8DEM

Edited by

Robert Hertzberg and Louis Martin

## IN THIS ISSUE:

The Triflex

by Clifford E. Denton

How to Identify Foreign  
S.W. Stations

by Capt. H. L. Hall

Satisfactory Short-Wave  
Reception

by Arthur H. Lynch

The Maligned Modulator

by Robert S. Kruse

Getting Started on  
5 Meters

The Convertible 5

## THE TRIFLEX

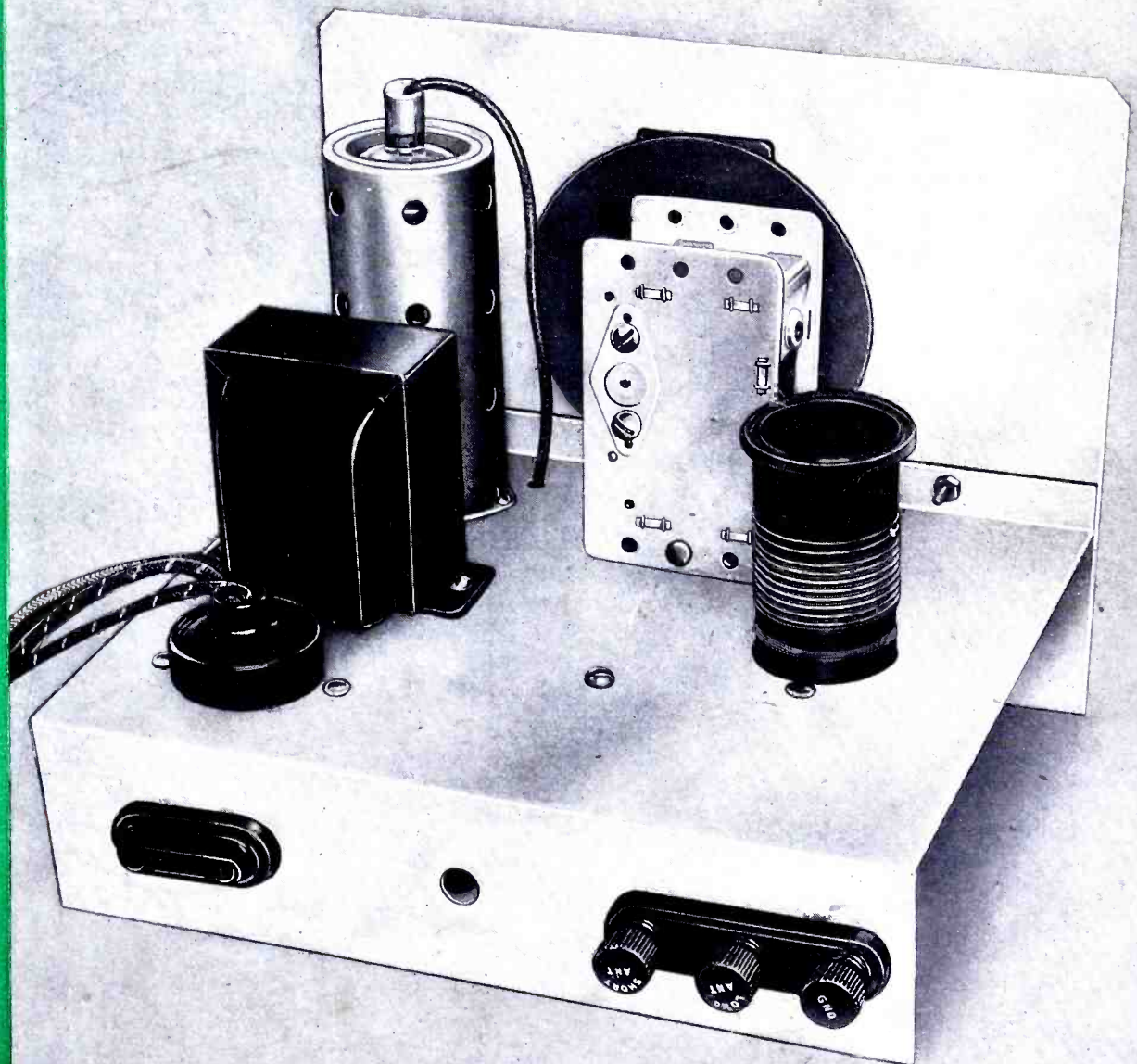

One Tube Does the Work of Three  
in this New S.W. Receiver



---

*Advance Announcement of the*

# Short Wave Radio HANDBOOK

By

CLIFFORD E. DENTON

*Ready about Dec. 1, 1933*

● The new SHORT WAVE RADIO HANDBOOK will be the answer to the short-wave fan's prayer for a readable, understandable book that explains the mysteries of high-frequency radio without adding any mysteries of its own because of obscure technical wording. This book will not be a long and exhaustive volume, but rather a concise work from which you will receive immediate enlightenment on many confusing phenomena that you encounter in your everyday radio experimenting.

● One half of the book will contain explanatory text and much useful data; the other half will be devoted to descriptions of a variety of new and representative short-wave receivers, designed by Mr. Denton, never before shown in print.

● Clifford E. Denton, well known to all readers of radio publications, is one of those rarities of the publishing business—an accomplished engineer who can write

on highly technical subjects in simple, lucid language, thoroughly understandable to the layman. A graduate of both Stevens and Columbia, and the holder of four degrees, his high standing as a technician is universally acknowledged, while his ability as a writer has made him widely popular with the people who find short-wave radio such a fascinating hobby.

● The book will run to about 128 pages and will be worth its cost many times over to every radio fan. This preliminary announcement is being made now to give readers of SHORT WAVE RADIO an opportunity to place orders for their copies before printing and paper costs assume an inevitable increase. Order now and save yourself money later!

● United States stamps, money orders and bank checks accepted. If you want to send a dollar bill, please wrap it in several layers of paper.

*Special price \$1.00 postpaid*



Standard Publications, Inc., 1123 Broadway, New York, N. Y.

---



J. E. Smith, President, National Radio Institute, the man who has directed the Home-Study training of more men for the Radio Industry than any other man in America.

# BE A RADIO EXPERT

## Many Make \$40 \$60 \$75 a Week

### I'll Train You at Home in Your Spare Time for RADIO · TELEVISION · TALKING MOVIES



#### Set Servicing

Spare-time set servicing pays many N. R. I. men \$5, \$10, \$15 a week extra. Full-time men make as much as \$40, \$60, \$75 a week.

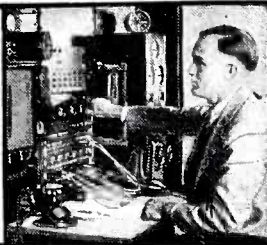

#### Broadcasting Stations

Employ managers, engineers, operators, installation and maintenance men for jobs paying up to \$5,000 a year.

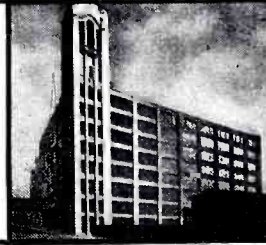

#### Radio Factories

Employ testers, inspectors, foremen, engineers, service men, for jobs paying up to \$7,500 a year.

#### Aircraft Radio

Radio is making flying safer. Radio operators employed through Civil Service Commission earn \$1,620 to \$2,800 a year.



#### Talking Movies

An invention made possible by Radio. Employs many well-trained Radio men for jobs paying \$75 to \$200 a week.



#### Television

The coming field of many great opportunities is covered by my course.



If you are dissatisfied with your present job, if you are struggling along in a rut with little or no prospect of anything better than a skinny pay envelope—clip the coupon NOW. Get my big FREE book on the opportunities in Radio. Read how quickly you can learn at home in your spare time to be a Radio Expert—what good jobs my graduates have been getting—real jobs with real futures.

### Many Radio Experts Make \$40, \$60, \$75 a Week

In about ten years the Radio Industry has grown from a few million dollars to hundreds of millions annually. Over 300,000 jobs have been created by this growth, and thousands more will be created by its continued development. Many men and young men with the right training—the kind of training I give you in the N. R. I. Course—have stepped into Radio at two and three times their former salaries.

#### Real Opportunities Ahead in Radio for Trained Men

It's hard to find a field with more opportunity awaiting the trained man. Why in 1932—the worst year of the depression—the Radio Industry sold \$200,000,000 worth of sets and parts! Manufacturers alone employed nearly 100,000 people! About 300,000 people worked in the industry. In 1932, broadcasting had a most profitable year. It's a gigantic business, even in the worst business years! And look what's ahead! Millions of sets becoming obsolete annually. 17,000,000 sets in operation that need servicing from time to time! Over 500 great broadcasting stations furnishing entertainment and news to 100,000,000 people. These figures are so big that they are hard to grasp! Yet, they are all true! Here is a new industry that has grown quickly into a commercial giant. No wonder great business leaders predict a brilliant future for this great and growing business.

#### Get Into This Field With a Future

There's opportunity for you in Radio. Its future is certain. Television, short wave, police Radio, automobile Radio, midjet sets, talking movies, public address systems, aircraft Radio—in every

branch, developments and improvements are taking place. Here is a real future for thousands and thousands of men who really know Radio. Get the training that opens the road to responsibility, good pay and success! Send the coupon now and get full particulars on how easy and interesting I make learning at home. Read the letters from graduates who are today earning good money in this fascinating industry.

### Many Make \$5, \$10, \$15 a Week Extra in Spare Time Almost at Once

My book also tells how many of my students made \$5, \$10 and \$15 a week extra servicing sets in spare time, soon after they enrolled. I give you plans and ideas that have made good spare-time money—\$200 to \$1,000 a year—for hundreds of fellows. My course is famous as "the one that pays for itself."

#### Money Back if Not Satisfied

I am so sure that N. R. I. can train you at home satisfactorily that I will agree in writing to refund every penny of your tuition if you are not satisfied with my Lessons and Instruction Service upon completion. You'll get a copy of this Agreement with my book.

#### 64-page Book of Information Free

Get your copy today. It's free to any ambitious fellow over 15 years old. It tells you about Radio's spare-time and full-time job opportunities; it tells you all about my Course; what others who have taken it are doing and making. Find out what Radio offers YOU without the slightest obligation. MAIL THE COUPON NOW.

J. E. SMITH, President  
National Radio Institute  
Dept. 3 MS8  
Washington, D. C.



## SPECIAL FREE OFFER

Act now and receive in addition to my big free book, "Rich Rewards in Radio," this Service Manual on D.C., A.C., and Battery operated sets.

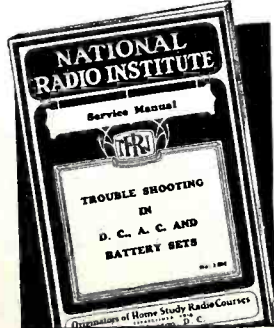

Only my students could have this book in the past. Now readers of this magazine who mail the coupon will receive it free. Overcoming hum, noises of all kinds, fading signals, broad tuning, howls and oscillations, poor distance reception, distorted or muffled signals, poor Audio and Radio Frequency amplification and other vital information is contained in it. Get a free copy by mailing the coupon at right.

THIS COUPON IS GOOD for One FREE COPY OF MY BOOK

mail it NOW

J. E. SMITH, President  
National Radio Institute, Dept. 3 MS8  
Washington, D. C.

Dear Mr. Smith: I want to take advantage of your Special Offer. Send me your two books, "Trouble Shooting in D.C., A.C. and Battery Sets" and "Rich Rewards in Radio." I understand this does not obligate me. (Please print plainly)

Name ..... Age.....

Address .....

City ..... State..... "M"

# SHORT WAVE RADIO

*devoted to short-wave transmission and reception in all their phases*

November, 1933

Vol. 1, No. 1

## IN THIS ISSUE :

By Way of Introduction.....	5
The Triflex—A 1-Tube Reflex by Clifford E. Denton	6
Capt. Hall Tells How to Identify Foreign Stations.....by Capt. H. L. Hall	10
Short Wave Short Cuts.....	13
Building and Operating the Convertible 5 by Robert Hertzberg	14
The Maligned Modulator by Robert S. Kruse	20
Why Skip Distances?.....	21
Stations of the U. S. S. R.....	23
Satisfactory Short-Wave Reception by Arthur H. Lynch	24
Notice to Contributors.....	26
Bringing the S. W. Receiver Up to Date..	27
Naval Time-Signal Schedule.....	30
Chart of Radio Symbols.....	31
The Denton Trophy Contest.....	32
Short-Wave Station List.....	33
The Before Breakfast Short Wave Club....	36
How to Get Started on 5-Meter Work by Arthur Hertzberg	38
Not the "How" but the "Why" of Super- heterodynes.....by L. van der Mel	41



Louis Martin

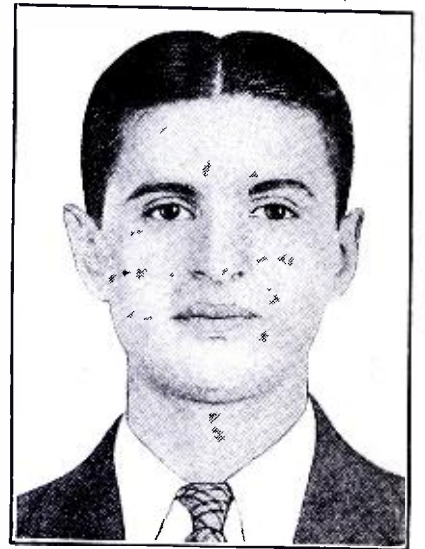

Robert Hertzberg

## IN FUTURE ISSUES:

Interest in short-wave transmission is increasing by leaps and bounds. Future issues will therefore contain much "dope" on modulation, antenna systems, high-voltage power supplies, microphones and other important problems.

More new tubes are coming! Full characteristics and hints on practical applications will be given. A schematic diagram, clear photographs, and a detailed description of the receiver selected for the 1934 Byrd Antarctic Expedition—something worth waiting for.

The entire contents of SHORT WAVE RADIO is copyrighted by Standard Publications, Inc., and must not be reproduced without permission of the copyright owners.

SHORT WAVE RADIO—Monthly. Application for second-class mailing entry filed at the post office at Chicago, Illinois, under the act of March 3, 1879. SHORT WAVE RADIO is published on the first of every month preceding date of issue. Subscription price is \$2.50 a year in the United States and possessions; Canada and foreign countries, \$3.00 a year. Individual copies, \$.25 in the United States and possessions; Canada and foreign countries, \$.30. Editorial and advertising offices, 1123 Broadway, New York, N. Y. Published by Standard Publications, Inc., 4600 Diversey Avenue, Chicago, Illinois. Louis Martin, President; Robert Hertzberg, Secretary-Treasurer. Send all manuscripts to SHORT WAVE RADIO, 1123 Broadway, New York, N. Y.

# Ship aboard a SCOTT ALL-WAVE *Deluxe* for a THRILL CRUISE 'ROUND THE WORLD

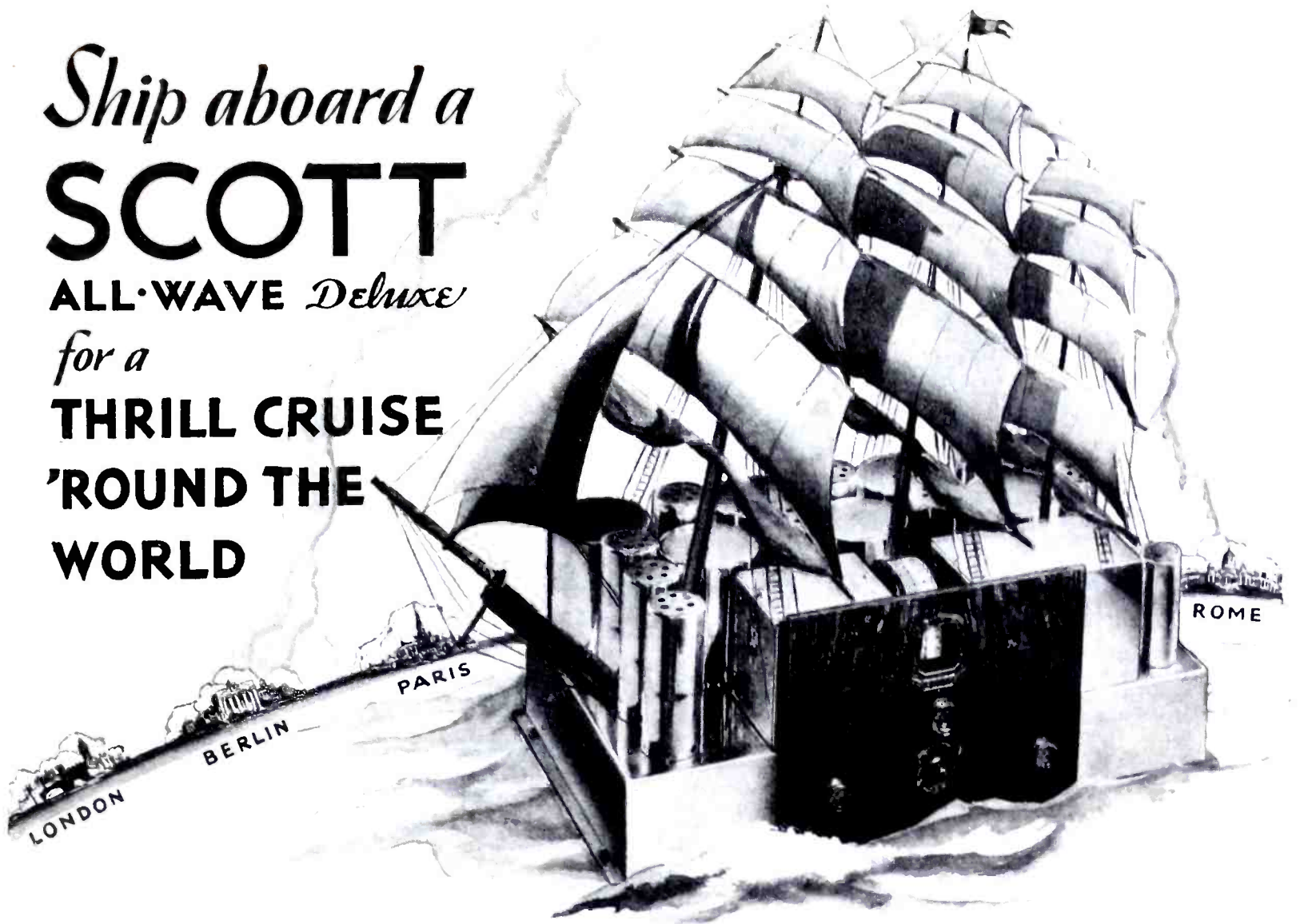

If you're an adventurer at heart (and aren't we all?) you'll glory in the thrills of cruising the ether-waves via a SCOTT ALL-WAVE *Deluxe* Radio.

Sit right in your own comfortable living room . . . there's no sea-bag to pack, no dunage to stow, no passports to secure. Just the twist of a single, simple tuning dial and it's "Ho! You're off for strange lands of romance and allure!"

### *Supreme for Stay-at-Home Listeners*

First a shake-down cruise in home waters. Listen in on American broadcast stations near and far—coast-to-coast is an easy jaunt. Discover the marvelous capability of this dream ship to carry you anywhere at your will . . . with a delightful fidelity of tone that puts you right into the sending studio, giving you every word of speech and every note of music with a glorious perfection that transcends all previous heights of mechanical sound reproduction. Your own ears will tell you so . . . and the evidence is backed up by scientific laboratory findings that prove SCOTT radio reproduction to be the closest to perfection yet attained.

As a first venture in short wave reception listen-in on the crime wave as reported by police calls from one end of the land to the other . . . eavesdrop on gossipy amateur wireless telephony "hams", and hear the airplanes and their ground stations talk back and forth.

### *Hear Canada and Mexico*

Now venture farther! Roam the air-waves to Canada and Mexico. Hear something different . . . something typical of these near-by foreign lands broadcast on wave bands from 15 to 550 meters. Don't fret about the rumors you may have heard that these countries are soon to change wave-lengths . . . your SCOTT can be equipped to receive on all bands between 15 and 4,000 meters at a small extra charge.

### *Listen-in On All of Europe*

And now you've "got the feel of your ship." Head out into the open . . . start on a fascinating exploration cruise for radio joys that are new and different.

Here's England, first! GSB, at Daventry, is sending out the news of the day for the benefit of Colonial

listeners-in . . . there's peppy music from a famous London hotel . . . and at signing off time (midnight in London, but only 6 P.M. Central Standard Time) the chimes of Big Ben, atop the Houses of Parliament, clang sonorously as though you were actually there to hear them in person.

Slip your moorings once again. Cross the Channel and lend an ear to Radio Colonial, Pontoise, France. It's bringing you Parisian music and typically French entertainment.

### *Varied Programs from Far Countries*

Distance still lures you! Then set your course for Germany . . . In a jiffy you're listening to Zeesen, with programs of glorious symphony orchestras, and perhaps a speech by "Handsome Adolph" that will give you a different viewpoint on Hitlerism.

Make port at Madrid, in sunny Spain, and hear EAQ broadcasting typical National music. Announcements from this station are considerably made in English as well as Spanish.

Then swing south to Rome and hear the voice of 12RO's woman announcer tell you it's "Radio Roma, Napoli," that's on the air. Most likely the following musical program will be opera direct from LaScala, in Milan, or some other musical treat worth going actual miles to hear—and you'll be listening to it, with purity of tone and richness of reproduction that's truly amazing, without stirring from your easy chair at home.

And now for an adventure-trek that holds a supreme "kick" for the radio sensation-seeker! Sail away "down under." Listen in to VK2ME or VK3ME, in Sydney and Melbourne, Australia. Hear the call of that famous Kookaburra bird, listen with delight to an interesting and varied program of music and talks on the commercial and scenic attractions of the Antipodes.

### *Owners' Reports Show Real Ability*

And these are but a few of the interesting places to be visited by means of your SCOTT ALL-WAVE *Deluxe* Receiver . . . F. L. Stitzinger, for instance, is a Scott owner who in a six-month's period received 1588 programs from 41 stations in 22 foreign lands. A. G. Luoma got 1261 programs from 75 different stations in 26 countries, and some 200 other SCOTT owners reported reception of 16,439 programs from 320 stations in 46 countries during the same time.

"Can such startling radio performance be true?"

you ask. Do you doubt that any but radio professionals can enjoy the delights of exploring the air-waves the world over, far from the too-familiar programs of broadcast stations here at home? Do you think that it may be possible, but feel that the cost of sufficiently able equipment is more than you can afford for entertainment?

### *New Value at Moderate Cost!*

Then set your mind at ease! For such performance is actually possible . . . we gladly prove it to you, and back the proof by an iron-clad guarantee of consistent foreign reception.

Laboratory technique, employing the world's most skillful, specially trained engineers and craftsmen in custom-building a receiver constructed to the highest standards of perfection known in radio, makes possible the super-performance of the SCOTT ALL-WAVE *Deluxe* for any radio-user, regardless of his experience or skill in operating. In this set top efficiency is coupled with absolute simplicity of tuning.

Prohibitively high priced? Not at all! You can have a SCOTT, and enjoy the supreme thrill of mastering the air-waves of all the world, at moderate cost.

### *Get Complete Details—Mail Coupon!*

Because the SCOTT ALL-WAVE *Deluxe* is one of the truly fine things of the world, custom-built for those discriminating people who demand the best, it is not distributed broadcast, to be casually picked up here, there, or anywhere. To get full particulars regarding it, absolute PROOF of its performance, and all the information you require, simply send the coupon below direct to the modern scientific laboratories where it is built.

.....  
E. H. SCOTT RADIO LABORATORIES, INC.  
4450 Ravenswood Ave., Dept. SWR-113 Chicago, Ill.

Tell me how I can have a SCOTT ALL-WAVE *Deluxe* to take me radio world-cruising. Include all technical details, proofs of performance, and complete information.

Name.....

Address.....

City.....State.....

# Don't Let Him Get FAT



## On YOUR Time!

### He'll Soon Eat You Out of Your Service Business

The proper kind of service information will kill that animal. Rider's Manuals give you the service information which will banish waste and loss of time during service operations. No longer is it necessary to hunt—guess—experiment and hope that you are right. *Hunting and guessing cost you money.*

Sets with whiskers are as easily serviced as the very new ones. Nothing is a secret in a commercial receiver when you own Rider's Manuals. Upside-down servicing (chassis turned upside-down) is as easy as you want it to be. You don't have to be a Sherlock Holmes when you have these Manuals because the hard-to-get and seldom-heard-of circuits which cause so much trouble for the service field are in these Manuals.

No more guessing at peak frequencies—or hunting for trimmers and tracing of power transformer leads. All of this material is in the Manuals. No more wishing you had the circuits. They ARE there! Right in the Manuals. You don't have to gaze into a crystal ball to learn what units are in sealed cans and the circuit. This information is shown in Rider's Manuals.

Banish waste and loss of time! Make every minute on the job a *paying minute*. Get Rider's Manuals—they will pay for themselves many times over.

*The fact that these Manuals are the finest in every respect and will be of tremendous aid is proved by their use and recommendation by such famous tube companies as RCA Radiotron, E. T. Cunningham, Inc., National Union Radio Corp.—such famous instrument manufacturers as Weston, Hickok, Readrite, etc., and such famous set manufacturers as Stromberg-Carlson, Fada, All-American, Grigsby-Grunow, etc.*

Rider's Manuals, Volumes I, II and III cover receiver production from 1919 right up to the minute. Volume III contains the receivers produced during the last year, inclusive of about June, 1933. Volume II contains the earlier productions. Volume I contains the receivers from 1919 to about May, 1931. **ABSOLUTELY NO DUPLICATION OF CONTENTS IN THESE MANUALS!**

Start your Rider's Manual library today. Each volume is self-contained and does not duplicate. Each has a complete index. Each is available with a *money-back guarantee!*

## A NEW Rider MANUAL Specialized Auto Radio Manual Volume I

*Loose leaf ☆ About 300 pages ☆ Up To The Minute*

Here is a specialized Auto Radio Manual which contains *all* auto radio receivers—old and new—for the auto radio specialist.

This manual has no equal. . . . It contains more pages than any other auto radio manual. . . . It contains more receiver schematics than any other auto radio manual. . . . It contains more information—old and new—than any other manual.

Rider's Specialized Auto Radio Manual—the Rider Manual in the brown cover—contains the very latest auto radio receivers and the old ones too. It contains schematics—chassis layouts—voltage data—resistor data—electrical values—point-to-point data—socket layouts—installation data—antenna data. Everything you need.

**Price \$3.50 Postpaid**  
*Get Your Copy Today! Sold With a Money  
Back Guarantee!*

## Perpetual Trouble Shooter's Manual

Volume I, \$7.50

Volume II, \$6.00

Volume III, \$7.50

COUPON

..... Volume I  
..... Volume II  
..... Volume III  
..... Specialized  
..... Auto Radio Man'l

**John F. Rider, 1440 Broadway, New York, N. Y.**

Enclosed you will find \$..... for which you will send at once postpaid .... Volume I .... Volume II .... Volume III of Rider's Perpetual Trouble Shooter's Manual .... Specialized Auto Radio Manual. If I am not satisfied, and return the manual within 10 days after receipt and in perfect condition, you will immediately refund my money.

Name.....  
Address.....  
City..... State.....

# SHORT WAVE RADIO

*devoted to short-wave transmission and reception in all their phases*

Robert Hertzberg, *Editor*

Louis Martin, B.S., *Technical Director*

General Advertising and Editorial Offices, 1123 Broadway, New York, N. Y.

November, 1933

Vol. 1, No. 1

## By Way of Introduction

**W**HAT, another magazine? Yes, another one; but this magazine is designed to cover a specific field for a specific group of readers. In short, this magazine is for the short-wave listener and, of course, will feature short-wave apparatus. We say apparatus because we do not mean receivers alone; we intend to run anything whose field of application lies below 200 meters.

It may be news for some people to know that there are about 70,000 short-wave fans aside from the transmitting hams, and that the thirst of these 70,000 people must be quenched. It is the purpose of this magazine to do the quenching.

We believe we are qualified to know what you want and must have. Robert Hertzberg, associated with radio since the old spark days, formerly managing editor of RADIO NEWS and RADIO DESIGN, and associate editor of RADIO-CRAFT and SHORT WAVE CRAFT, is probably better qualified to realize the needs of short-wave listeners than any one else in the field. Louis Martin, formerly managing editor of RADIO CRAFT, and a man of rigid technical morals, will see to it that the apparatus run in this magazine are as good in actuality as they sound on paper. We want to go on record right here and declare that no receivers will be described that have not passed a satisfactory test by the editors.

**A**SIDE from the short-wave articles, we will also publish considerable material on the ultra-short-waves. We firmly believe that the very short waves will be the resting place for television when it finally peeps around that mysterious corner. Our readers will be kept well supplied with information along these lines.

Because of the simplicity of ultra-high-frequency apparatus, it is our intention, also, to print information on small transmitters suitable for

these bands. There is a very fruitful field for the experimenter here, as contrasted with the relatively well-explored low-frequency channels.

The five-meter band, for instance, is suitable as "meat" for the short-wave fan. Super-regeneration is used in this band almost to the exclusion of all other circuits; it is our intention, under these conditions, to give a comprehensive description of super-regeneration in an early issue in order to strengthen the requirements for successful operation of such circuits in the minds of our readers.

**O**UR policy, both editorial and advertising, is simple and straightforward. Editorially, we will run whatever the readers demand; the only requirement is that the material must pertain to the short-wave band. As for our advertisers, only those who are recognized as representing the highest calibre in the field will be represented. It is not our intention to fill the book with the many gyps which infest the market. In fact, we welcome and request comments from readers regarding the service rendered by our advertisers. We are an entirely independent organization with no commercial axe to grind.

**T**HIS issue is, necessarily, small. The physical size of the magazine will increase as new material comes in. We do not believe in publishing a large book and have 50 per cent of it full of plain junk in order to fill it; we prefer quality to quantity. We feel sure that by the time the third or fourth issue rolls around, the size of SHORT WAVE RADIO will have increased materially.

That is our stand. We believe we know what you want and how you want it. If we do our part, we feel sure that you will do yours. If you are ready, then turn over and start right in.

# The TRIFLEX

## A 1-Tube Reflex

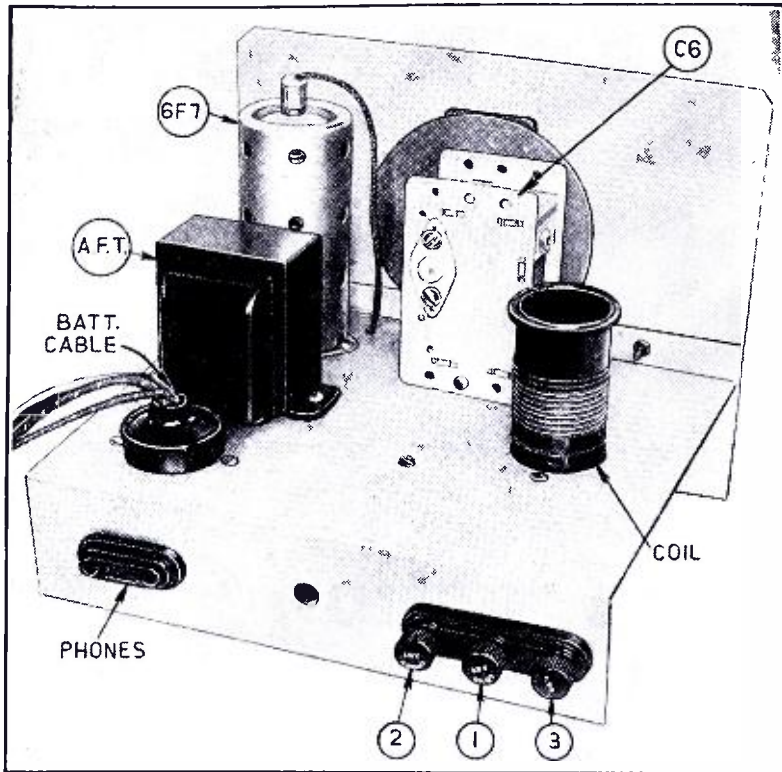

**THE TRIFLEX:** Here is a really good article describing a really novel short-wave receiver. Sensitive short-wave sets have been described many times in the past; our aim now is to present a one-tube receiver with greater sensitivity than is usually obtained in one-tube sets. We believe Mr. Denton has made good. The "Triflex" uses a single 6F7 tube in a unique reflex arrangement that promises to be one of the best possible. Regeneration in one section of the tube further increases the sensitivity. Tests made in our own laboratories convinced us that the "Triflex" is about the best single-tube receiver that we ever listened to.

**N**EW circuits and tricky apparatus have always interested radio experimenters. The possibility that nearly every new circuit will deliver unbelievably loud signals when tuned to unbelievably weak stations always persists back in the mind of the dyed-in-the-wool fan. To date, nothing so radical has appeared. New circuits, of course, are always available; but upon detailed inspection, one usually finds that either the color of the wire has been changed or that a tube has been placed horizontally instead of vertically. In plain English, only a radical change in both tube and circuit design can produce results that are radically different from those now secured with standard apparatus.

The reflex receiver heralded some six years ago as the outstanding achievement of the age is with us again. We say "again" for the simple reason that its popularity was only temporary, for it soon was cast into oblivion with hundreds of other sets of like nature. The fundamental concept upon which the popularity of the reflex was founded is still a sound one: the high cost of tubes and the necessity for continually recharging batteries made it desirable to design a circuit in which a single tube replaces the usual two or three tubes. Upon this premise, the reflex was designed. As other experimenters added bits and subtracted bits from the original circuit, new features, some surprisingly inconsistent, were credited to the reflex. Then, as new tubes were manufactured, and as the prices of these new tubes were reduced, the necessity for having one tube do the work of two or three was removed, and, consequently, the reflex faded out.

During the past year or so, engineers have again turned their at-



**By Clifford E. Denton**

Well-known short-wave engineer, who has probably developed more short-wave equipment for the experimenter than any other man.

tention to the reflex receiver, but this time with a little different thought in mind: small space and economy of operation are now generally conceded to be the only outstanding advantages of the reflex. Here is where the commercial engineer stops and where the amateur begins. Everyone who has followed the new tube announcements during the past year and a half has probably come to the conclusion that these new tubes are too complex for all but the well-groomed scientist. Tubes with seven grids, tubes with two and three plates, tubes with their elements placed in somewhat mystical and confusing positions, are thrust at the unsuspecting, and

usually placid, public with such speed that it will probably be years before the amateur experimenter familiarizes himself with all of their working characteristics.

### The "Triflex"

Out of this confusion the writer picked the 6F7 as the basis of a one-tube receiver connected in a reflex arrangement of such stability as to astound all those who have listened to this little set perform. Now, we do not wish to point out that this is *the* circuit. We do not wish to state that this receiver can produce unbelievably loud signals when tuned to an unbelievably weak station. We do say, though, that this one tube can be connected to act as an r.f. amplifier, a regenerative detector, and as an audio-frequency amplifier, and that this circuit has out-performed, both as regard sensitivity and volume, any other one-tube set yet heard by the writer.

The reflex circuit is a bit tricky if you do not know what makes the wheels go round, so we are going to start off on the right foot and give an elementary discussion of not only what makes the wheels go round, but what makes the *signals* go round. The little sketch of Fig. 1 tells the story graphically. By following the arrows, you see that the signal from the station is fed to an r.f. amplifier (untuned in our case), then to a tuned detector (which is regenerative), out from the tuned detector back into the untuned r.f. amplifier to the phones or loud-speaker. In the diagram, the solid lines represent r.f. energy and the dash lines audio energy. The fundamental operation of the receiver is simple: all signals picked up by the antenna are amplified by the untuned r.f. amplifier; the output is



**SUMMARY:** This article treats in detail the theory, operation and construction of a single tube reflex receiver called "The Triflex." The reflex receiver had its day about five or six years ago; but, because of the inefficiency of tubes in use at that time, and because of the comparatively low cost of apparatus, it was discarded in favor of the more stable and complex, straight, tuned r.f. set.

The reflex is here again; the new tubes have revived it. The modern reflex is not the conglomeration of tricky circuits that made every builder turn grey over night; with a little care it can be made to perform the function of three tubes in one with perfect stability.

The "Triflex," as the name implies, is a 1-tube reflex performing three operations at the same time, and uses the new 6F7 tube, a combination triode and pentode, in a circuit that is easy to build and that really works. Read the article by Mr. Denton and convince yourself.

then fed to the tuned detector, which selects the desired signal by means of a tuned circuit; the output of the detector, which is audio, is fed back again to the untuned r.f. amplifier, which now acts as an audio amplifier, to the phones. Thus, if all of these functions were performed by a single tube, we would have three operations: untuned r.f. amplification, detection, and a.f. amplification. The Triflex *does* perform these functions—hence its name.

### How the "Triflex" Works

How these functions can be performed in one tube can only be appreciated after a study of the internal construction of the tube itself. A drawing which mechanically shows the arrangements of the elements is shown in Fig. 2. The tube is seen to be composed of two separate and distinct sections, an upper section and a lower section. The lower, or first, section is a simple, ordinary, garden-variety of triode, similar in construction to the 27 type tube with which we are all familiar. The upper section is a simple pentode, similar in construction to the 47, 58, 57, etc. The heater and the cathode of this tube are common to both sections. In other words, one cathode serves both the triode and pentode sections of the 6F7. Other than this, the elements are distinctly separated, as seen from the tube-prong connections shown in the lower part of the sketch. It is easy to see, therefore, why we can take a signal from the antenna, feed it into the pentode section, amplify it, then feed it into the triode section, where it is detected, and, finally, again connect it to the pentode section, as shown in the block diagram of Fig. 1.

The development of the circuit, therefore, merely consists in developing individual units, and interconnecting them so as to give the desired results. Let us first develop our pentode circuit, then our triode circuit, and then interconnect the two.

Figure 3 is a simple r.f. amplifier used extensively in short-wave work. The condenser C1 is a small variable

unit connected in series with the antenna when the No. 1 antenna post, intended for long antennas, is used. If a short antenna is used, then it should be connected to post No. 2. R.F.C., connected between post 2 and ground, is a standard radio-frequency choke with an inductance of about 2½ millihenries. Condenser C7 is a bypass condenser for the grid-bias resistor R2. One end of R.F.C. connects to the control grid of the tube, the screen grid goes to B plus 100 volts, the suppressor grid connects internally to the cathode, and the plate connects to the primary of the r.f. transformer labeled L. There is nothing complicated or mystifying about this connection. It is perfectly stable in operation and should be very easy for any constructor to build.

Our triode section shown in Fig 4 is a simple, three-circuit arrangement, familiar to all short-wave fans. Several unique characteristics of this circuit set it apart from the more conventional arrangements. The coil L is the same coil L used with reference to Fig. 3, so that now we see that the output of the pentode section connects to the input of the triode section by means of L; condenser C6 is the tuning unit; R3 and C4 are the conventional grid-leak and condenser combination; C5 is the small r.f. bypass condenser; R.F.C. of course, is an r.f. choke, similar to that used in the antenna circuit; condensers C2 and C3 are bypass units whose function will be explained shortly. Now, putting the whole circuit together, we have

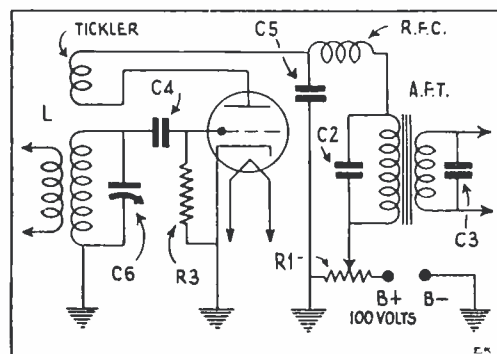
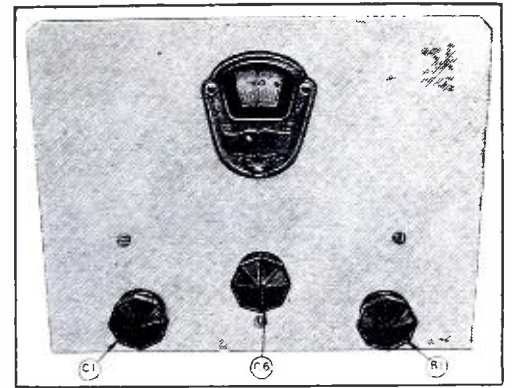

FIG. 4—THE TRIODE SECTION. Here is the output section of the tube, which, in turn, again feeds the input.



PANEL VIEW OF THE "TRIFLEX." Left to right: antenna condenser, tuning condenser, and regeneration control.

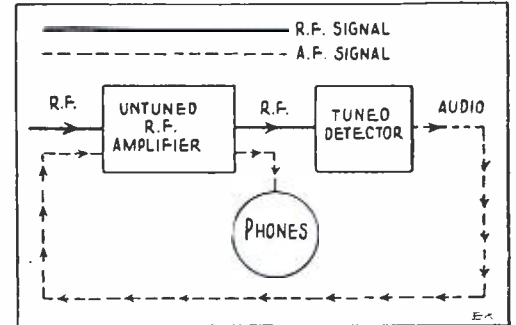

FIG. 1—BLOCK DIAGRAM OF THE "TRIFLEX." The solid line corresponds to r.f. and the dotted lines to audio signals.

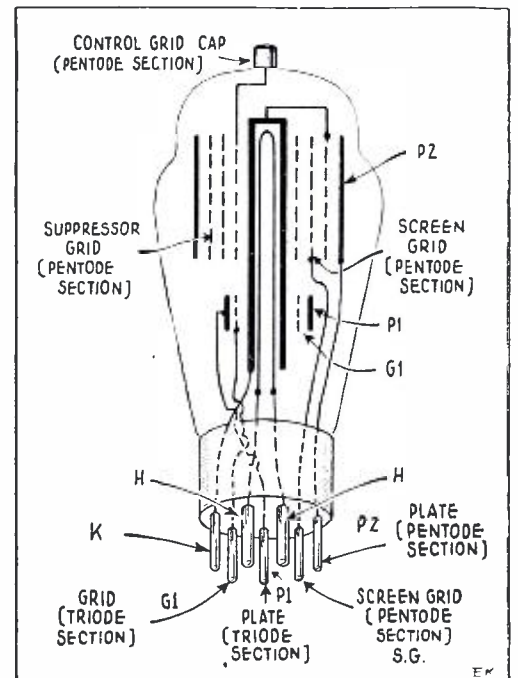

FIG. 2—THE 6F7 TUBE. This diagram shows internal construction and prong connections of the 6F7.

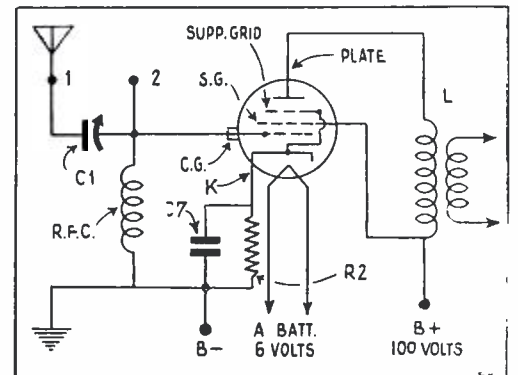
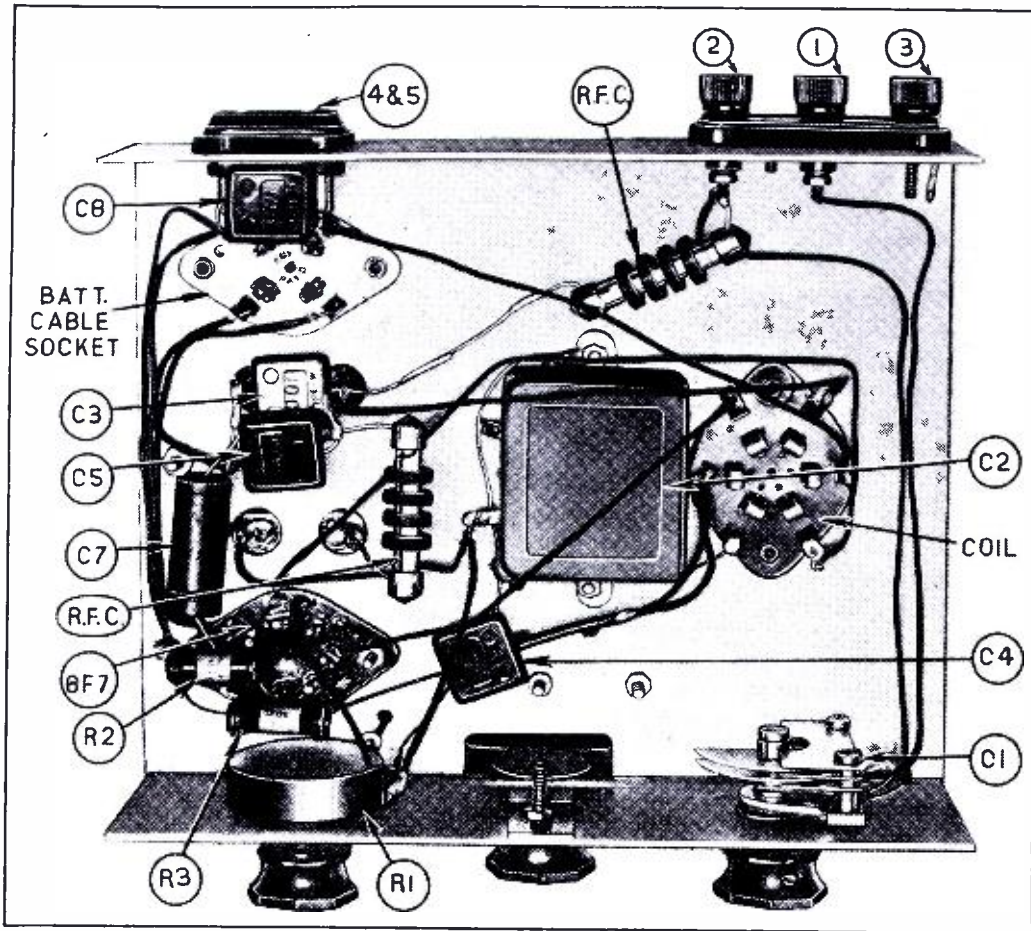

FIG. 3—THE PENTODE SECTION. Illustrating the input connections of the "Triflex." This is not reflexed.



PHOTOGRAPH OF THE UNDER SECTION OF THE "TRIFLEX."

Fig. 5, which we will examine in detail.

The antenna connects through condenser C1 to the choke, and from the choke to the control grid of the pentode section of the 6F7. The other end of the choke connects to the secondary of the a.f. transformer which is shunted by condenser C3. Note particularly that the cathode of the 6F7 connects to ground

through R2 and C7, and that one end of C3 connects to ground. Since C3 is of such size as to offer little reactance to the flow of the very high-frequency currents used in short-wave work, the lower end of the antenna choke connects to R2 through C3, as far as the r.f. signal is concerned. We will come back to this unit a little later. The plate of the 6F7 connects through the

primary, P, of r.f. coil L, then through a pair of phones, or loudspeaker, to B plus 100. The secondary of L is tuned by C6, and fed to the grid of the triode section. The plate of the triode section connects through the tickler and an r.f. choke to the primary of an a.f. transformer, the secondary of which connects to the antenna choke.

The signal, after being amplified by the pentode section, is still r.f., and since condenser C8 is connected directly across the phones, it bypasses this r.f., and conditions are exactly the same as if the phones were not present. The voltage induced in the secondary, S, by the primary actuates the grid of the triode section, which rectifies the signal and feeds it through the primary of A.F.T. Condenser C2 across the primary is used for the purpose of bypassing any r.f. that may remain in the triode plate circuit. The audio voltage now across the secondary is fed back to the pentode, where it is amplified again, and passes through the primary of L until it reaches the phones. Since this signal is now audio, coil P, which is extremely small, can have little effect on it; likewise condenser C8, having only a small reactance to a.f., is not affected, so that the signal is heard in the phones.

If condensers C2 and C3 were too large, some of the audio would be bypassed; particularly if C3 is too small, we would lose r.f. signal strength because some of it would have to go through the secondary of A.F.T. If condenser C8 were too small, some of the r.f. would have to go through the phones, and again we would lose signal strength; on the other hand, if it were too large,

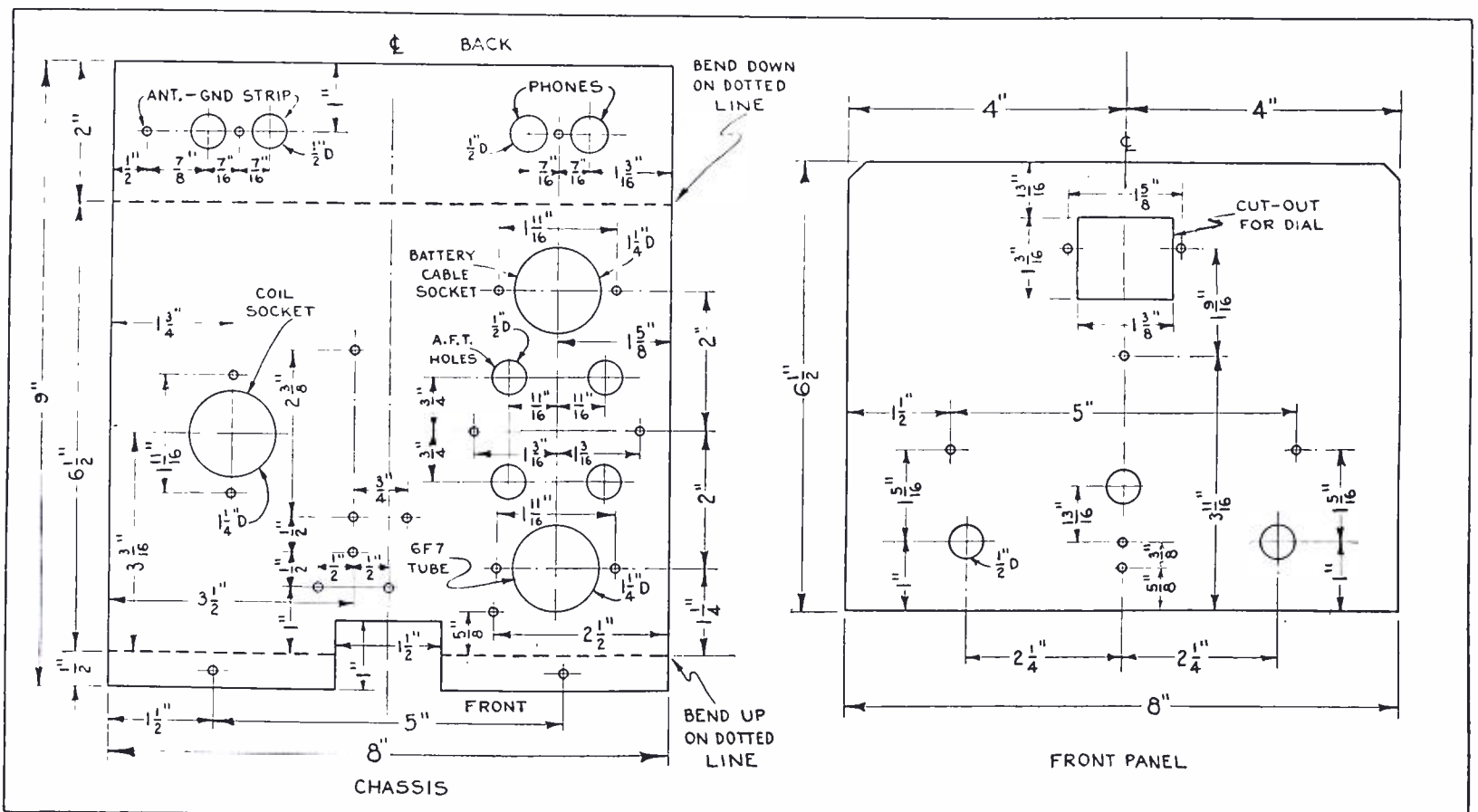

COMPLETE MECHANICAL DRAWING OF THE CHASSIS AND PANEL OF THE "TRIFLEX."

we would lose some of our audio signal. Thus, we see that the values of capacities used in the "Triflex" are fairly critical, and must not be deviated from by more than about 50 per cent.

Various views of the receiver are shown in the photographs and in the pictorial diagram shown here. The front view of the set shows three knobs, whose functions are as follows: lower left, antenna condenser C1; center, main tuning dial for C6; lower right, regeneration control R1. The panel is made of 1/16 inch aluminum, 8 inches wide and 6 1/2 inches high. The subpanel upon which the apparatus is mounted is 8 inches wide, 6 1/2 inches deep and 2 inches high. The locations of the various parts are marked on the photographs. The rear view of the receiver shows the location of the 6F7 tube, the tuning condenser C6, the plug-in coil, the audio-frequency transformer, the plug-in socket used to feed the A and B supply to the set, the antenna-ground binding post strip, and the phone terminals. The underview shows the location of all the incidental parts used in the construction other than those mentioned. These parts are labeled for convenience.

The first step in constructing the receiver is to lay out the panel and base as per the detailed drawings given herewith. The sizes of all holes are marked, and the only diffi-

*(Continued on page 47)*

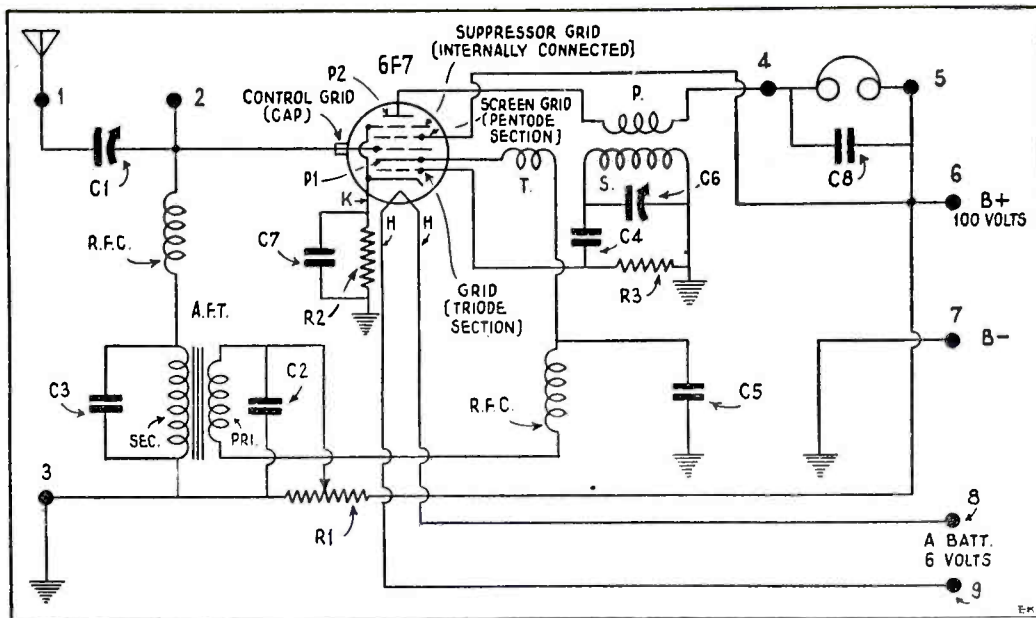
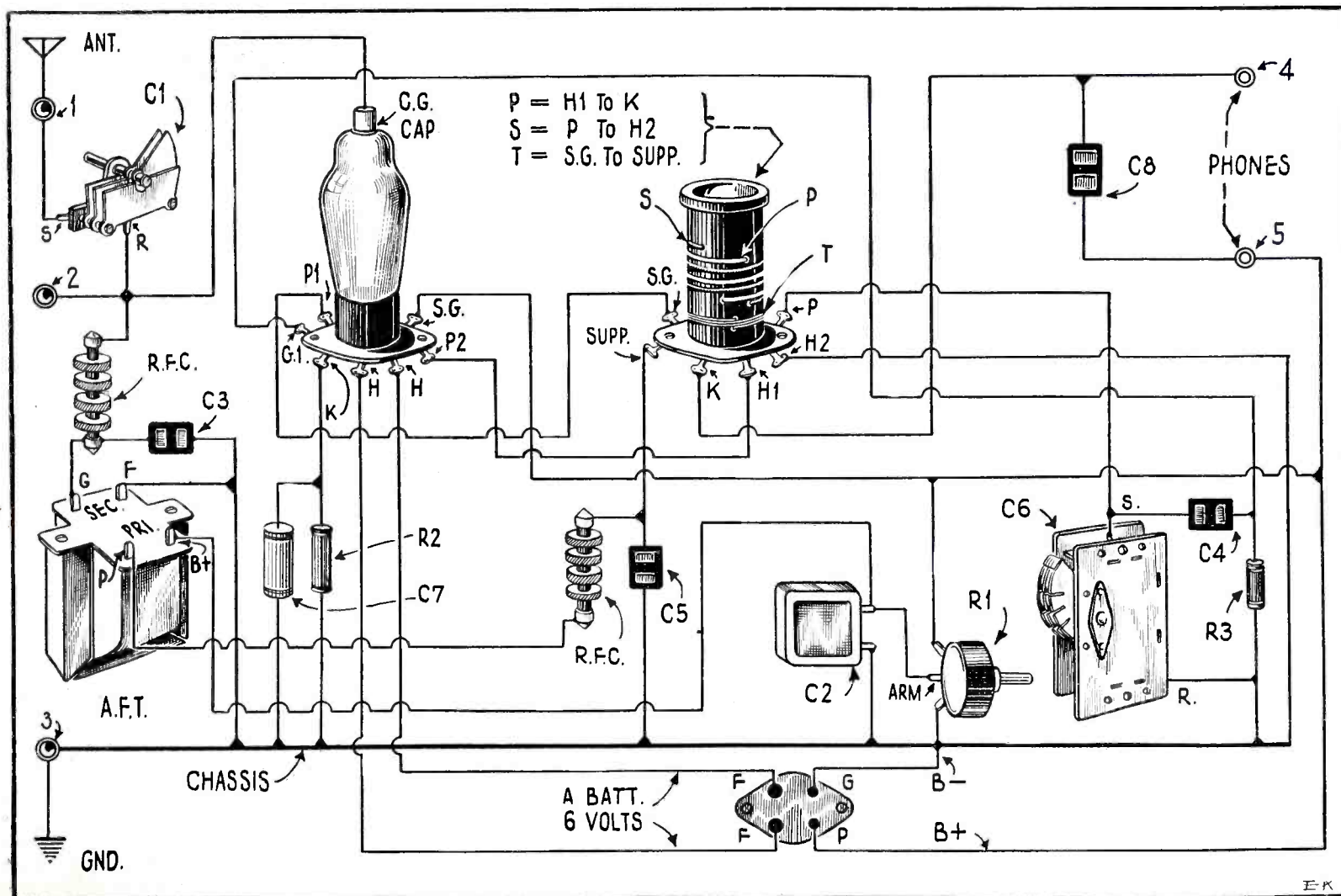

FIG. 5—SCHEMATIC CIRCUIT OF THE ONE-TUBE "TRIFLEX."

The complete list of parts for this set is listed below.

- C1—About 35 mmf. variable, with insulation washers (Acratest).
- C2—1 mf. bypass (Flechtheim G.F. 100).
- C3—.001 mf. mica condenser (Acratest).
- C4—.0001 mf. mica condenser (Acratest).
- C5—.00025 mf. mica condenser (Acratest).
- C6—.00015 mf. variable (Acratest No. 6854).
- C7—.1 mf. 200-volt tubular condenser (Flechtheim).
- C8—.001 mf. mica condenser (Acratest).
- R1—50,000-ohm potentiometer (Frost).
- R2—350-ohm, 1/2-watt resistor.
- R3—3 megohm, 1/2-watt resistor.
- R.F.C.—2 r.f. chokes, 2 1/2 millihenries (National, type 100). A.F.T.—audio-frequency

- transformer, about 3:1 ratio.
- 1—4-prong wafer socket for battery cable.
- 1—6-prong wafer socket for coil L.
- 1—7-prong small wafer socket for 6F7 tube.
- 1—4-conductor battery cable.
- 1—dial and drive unit (Acratest).
- 1—escutcheon plate for dial (Acratest).
- 1—metal panel and chassis as per data.
- 1—tube grid-clip.
- 3—knobs for controls (see photographs).
- 1—tube shield.
- 1—triple binding-post strip.
- 1—twin phone tip jack.
- 1—set of three-winding plug-in coils to cover the band from 10 to 200 meters (Alden).
- 1—6F7 tube.



A PICTORIAL VIEW OF THE "TRIFLEX" TO BE USED AS AN AID TO WIRING THE SET.

# Capt. Hall Tells How to Identify Foreign Stations

**SUMMARY:** Building a short-wave receiver is only half the job; the other half is to listen-in. Part of this second half of the job is covered by the station list; and the last part is to be covered in this department. Captain Hall, who is to conduct this monthly department, is one of the few experienced listeners with a critical ear, an excellent receiving station, and an enormous log of verified stations.

Verifications from listeners, especially outside of New York, are especially desirable, and will be published in this magazine with full credit. All verifications will be returned unaltered.

We wish to take this opportunity to thank Capt. Hall for his excellent cooperation in preparing this manuscript, and for his generosity in loaning us his original verifications for reproduction in this issue.



THE RECEIVING STATION OF CAPT. H. L. HALL

Two National receivers, a good antenna, and a pile of "veries" make up the "Captain's Bridge."

**D**X-ING—and in particular short-wave DX-ing—is one of the newer hobbies. How many fans who listen to programs from distant countries really have any thorough knowledge of foreign languages? Not many. Realizing this fact, and always trying to please the hard-to-satisfy fan, many foreign stations have adopted a plan by which the newcomer in the short-wave field and the youngest fan can easily tell just what country's broadcast they are listening to. This very convenient and most satisfactory idea has been so worked out by the individual stations that certain sounds or musical selections are definitely associated with the particular station transmitting them. No two stations use the same identifying signals. When one station broadcasts on several wavelengths, it uses the identifying signal that it adopts on all of them.

Let us go over the "foreign locals" first. When G5SW was England's "best bet," they always broadcast "Big Ben" whenever that world famous clock struck the hour. Now that Daventry has taken the place of G5SW, they also continue to use Big Ben's booming notes to tell the world that Great Britain is on the air. The announcer saying, "This is London calling the Canadian Zone," is known to all short-wave fans in this part of the world. Also,

when this station "shuts up shop," and the announcer, in a tired although very effective voice, bids his listeners, "Good-night, everybody," listeners really feel as though they should respond with the same phrase. "Big Ben" has definitely become known as Daventry's identifying signal.

Next we will listen to France. On the outskirts of Paris is located the town of Pontoise from which the French station has taken its name. When the Frenchman want us to know that they are coming on the air, they always play the "Marseillaise," the hymn dear to the hearts of all Frenchmen. At the beginning and close of all their short-wave broadcasts, Pontoise broadcasts this martial anthem. Following this is a station announcement in which no call letters are given; but fans are informed that "Radio-Coloniale" is about to begin their broadcast, "Hello, hello, ici Paris, Radio-Coloniale, 103 Rue de Grenelle."

Drifting further south we run into sunny Spain. Here we can almost tell without waiting for an announcement that the program we are listening to comes from EAQ, Madrid, Spain. Their music is very lively and, with a certain amount of imagination, one can almost see black-eyed señoritas singing and swaying to this music. At regular intervals a station announcement is

made both in Spanish and English; and even if the English announcement were abandoned, the Spanish one would be very easy to understand, as the announcer speaks slowly and distinctly—always the same. First, "Ay-ah-coo, Transradio, Madrid, Spain," followed by, "E, A, Q, Transradio, Madrid, Spain." At the close of the program, Spain's national anthem is played—a very inspiring and a very effective identifying signal.

If we were tuning on a Sunday we could go still further south to Africa to Rabat, Morocco, owned by the French. Again we run into a foreign language. Between selections which vary from high pitched native music to high-hat orchestral programs, we hear the Frenchman in Rabat—always the same—say, "Radio Rabat dans Maroc," and then comes the tic-tac, tic-toc of a metronome.

Let us go back to Germany, where Deutschlandsender's announcer signs off in German, English, and Spanish.

Up until a few months ago Germany used a tick of an alarm clock to tell the world it had been listening to Germany transmitting; but now they have decided that chimes playing eight bars from an old German song are more effective, and that is what the short-wave listeners now hear at the end of their transmissions.

Another European country that broadcasts chimes is Russia, which broadcasts midnight chimes from the Kremlin when it is five o'clock here in the States. Denmark, when broadcasting through OXY, tells the world it is midnight there by means of chimes, when we are just deciding that six o'clock is a good time to eat dinner.

A country that sends the gong of a bell into space is SR1 at Poznan, Poland. This station broadcasts bells from their City Hall, not at any definite hour, however. This station has a lady in a high voice and a gentleman in a deep voice who announce in this very clear fashion, "Hello, Hello, Polski Radjo-Poznan." This is spoken in Polish and French. Note that the call letters are also omitted. Previous to this announcement comes the identifying signals—a gong beaten for eleven seconds with stop intervals of eight seconds. This station has been heard by many who could not identify it.

Now we go to Italy. The lady with the oh! so lovely voice, is always there to say, "Radio Roma Napoli," whenever I2RO is broadcasting. Many a male heart has beaten just a little quicker when she spoke. We can hardly call a lady by so rude a name as an identifying signal, but this female voice has become known as Italy's identifying signal.

We will now go a little further from the city of Rome to Vatican City. When listening to HVJ, you will hear a gruff male voice shout, "Pronto, Pronto, Radio Vaticano" to tell the world they want to be listened to. But if you hear these "Prontos" calling ships, you will know it is IAC calling to the Italian ships.

"Coo-coo, coo-coo, coo-coo," Oh, we are now listening to Portugal. This active bird must be very hoarse by the end of a broadcast as he coo-coo's between every selection, and the selections are sometimes only a minute long. Long may he "coo," for many a fan has jumped in glee at the sound, as CT1AA in Portugal



By Capt. H. L. Hall

whose reception is the envy of all who know him.

is considered rather a difficult catch.

The League of Nations, still "parked" in Geneva, comes on the air once a week on Sunday to broadcast worldly troubles. The announcer says, "Hillo, Hillo, Radio Nations" and then announces in French before the French talk, English precedes the English talk, and the same with the Spanish transmissions.

Now that we have covered these two continents, let us skip to Australia, where the Kook-a-burra bird makes his home. If this native bird, that the Australians jestingly call the Laughing Jackass, has no other use in his home town, his call has been made world famous by being transmitted over VK2ME.

VK3ME has nothing as decidedly original as VK2ME's identifying signal, so they broadcast the 9:00 o'clock chimes in the evening when we here in the States are making up our minds to get up in the morning.

How many times have short-wave fans, when questioned on their ability to tune in numerous stations from foreign countries, alibied themselves by saying that they have so little time to tune because of their

business hours being so long that when they arrive home, all the stations worth going after have gone off the air? It has always been a belief held by the writer that the average enthusiastic short-wave fan can, if he wants to, pull in nearly every broadcast station worth hearing. Taking into consideration the fact that you have a receiver capable of this, let me tell a few instances of what the working man short-wave fan can get, again, I repeat, *if he wants to.*

Anyone who has ever lived or visited the part of town in the West Nineties in Central Park West, New York, realizes what terrible conditions a short-wave fan is up against. This section of New York City is honeycombed with seventeen-floor and higher apartment houses. Just think of all the electrical contraptions that the dwellers of these styles of homes use just for plain ordinary living! Electric fans, washing machines, driers and many others too numerous to mention.

Just a step from Central Park West, in a house only four stories high, lives a most interesting gentleman. His name is Max H. Bass, and to employ an expression new even to myself, he is a "hobbyist."

Short waves have intrigued him so, that, although he has devoted hours of study to all his other hobbies, he has one of the best collections of verifications that the writer has seen in many a day. His secret of arriving at his short-wave success is easily understood when one takes into consideration the fact that he does not tune haphazardly, but goes about his short-wave tuning intelligently.

He thoroughly believes in buying the best of anything pertaining to radio. For instance, he would rather deprive himself of some pleasure and use the cash for an excellent dynamic speaker. He has one of the best speakers I have ever heard. Formerly, he used a rather fairly well-built "home-made" receiver; but when he saw that a cer-

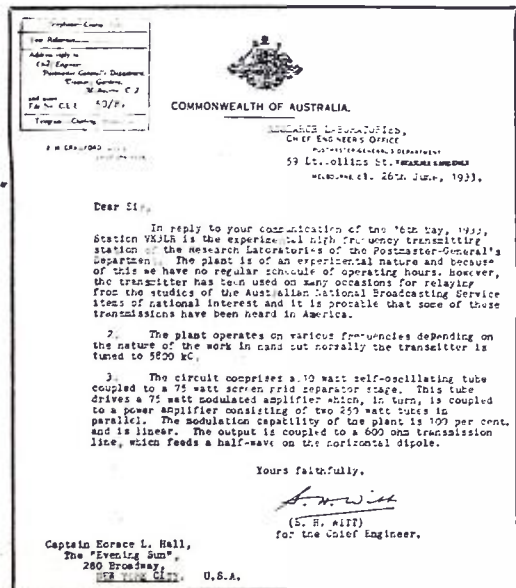

REPRODUCTION FROM AN ORIGINAL VERIFICATION

This letter verifies the reception of VK3LR by Capt. Hall.

VK2ME "THE VOICE OF AUSTRALIA"

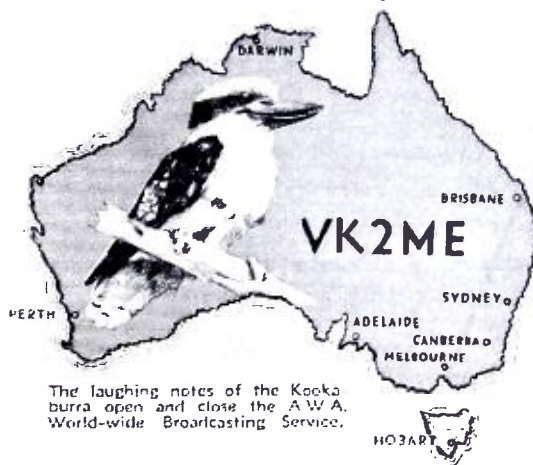

The laughing notes of the Kookaburra open and close the A.W.A. World-wide Broadcasting Service.

Power 20 Kwatts  
Wave-length 12 Meters

A. W. A.

Owns and Operates

Beam Wireless Services to Great Britain, The Continent of Europe, and North and South America

Wireless Telegraph Services to Great Britain, The Continent of Europe, North and South America, Japan and New Zealand

Coastal Radio Station in Australia, Papua, New Guinea and Fiji

Wireless Services on ships of the Australian Mercantile Marine

Radio-Electric Works for the manufacture of every type of transmitting equipment and Radiola broadcast receivers

Research and experimental laboratories.

World-Wide Broadcasting Service

AMALGAMATED WIRELESS (A/SIA) LTD.  
AUSTRALIA'S NATIONAL WIRELESS ORGANISATION



A VERIFICATION FROM VK2ME IN AUSTRALIA

Rear view of a verification sent to Capt. Hall by VK2ME. Note the Kookaburra.

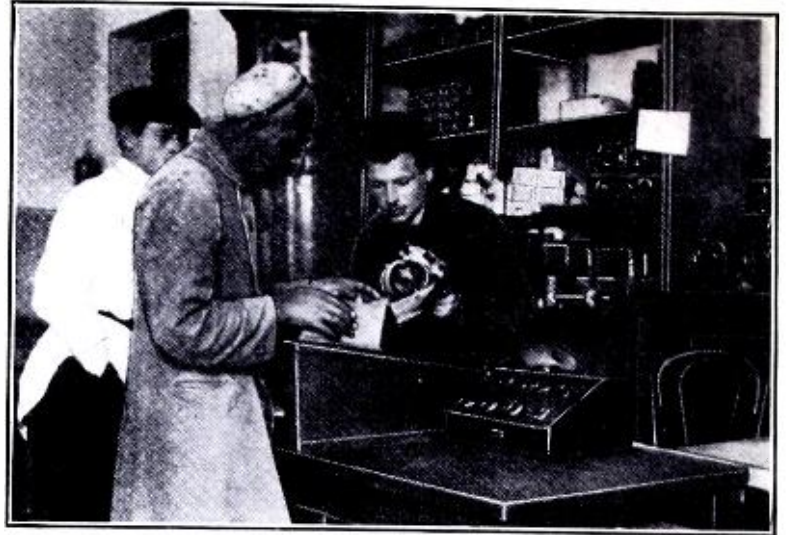
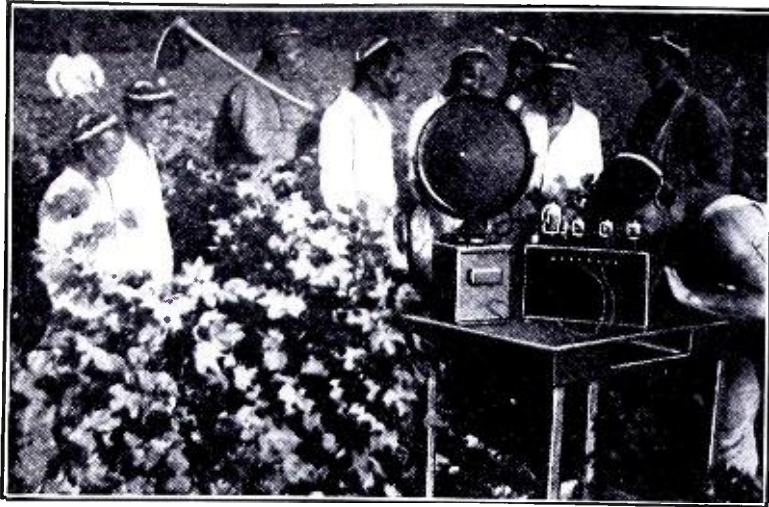

TWO RARE PHOTOGRAPHS OF RADIO CONDITIONS IN THE U. S. S. R.

These two photographs sent by RV59 in Moscow, shows, at the left, the education of peasants in the fields by radio. At the right, a typical radio store in the U. S. S. R. These pictures are typical of what can be received.

tain commercial receiver was "getting-the-world," he immediately made it his business to get one. He did so several months ago, and now has a flock of "veries" envied by many. He is the type of tuner that does not consider a station logged if it is not loud and clear enough to be heard on a loudspeaker, and he will not even mention that he heard them unless he has heard at least one station announcement. He is an extraordinary fan, and has been kind enough to give me a fine list of stations that have verified his reception of their broadcasts.

From Europe he has veries from G6RX, G5SW, GBS and all the Daventry's (England), France, Germany, Holland, Italy, Spain, Switzerland and Portugal.

He has a prized veri from OPM, the Belgian Congo, and also one from Rabat, Morocco. Veries from the two twin stations in Australia also have places of honor on his living-room wall.

And now getting nearer home, he has veries from the Hawaiian Islands, Honolulu, Mexico, Bermuda, all the short-wave stations in Canada, vari-

ous South Americans, and the S.S. *Majestic* when she was in mid-ocean.

Although Mr. Bass has little time for tuning, he has heard the whole world except the Asiatics, and he is not alone there. Many a fan has written and asked, "Why are there not more broadcasting stations in the Far East?" The only one that no one had much trouble in getting was F3ICD, Saigon, French Indo-China, and they went off the air a year or more ago.

A fan with a fine log is Mr. J. B. L. Hinds of Yonkers, New York. He is no newcomer in the short-wave field and certainly, from the lengthy logs he so kindly sent us, he must know his business when it comes to tuning his receiver. His log for the last month is worthy of mention: England, Holland, Rabat, Morocco, France, Australia, Italy, Germany, five stations in Canada, Switzerland, Spain, Costa Rica, Mexico, Venezuela, and many of the little Colombians.

Logs from foreign short-wave fans are interesting only when used for comparison with our's here in the States.

A Japanese fan sent along the fol-

lowing log: Three veries from the United States, ZGE, Malay States; SUV, Egypt; RUOK, China; France; England; Germany; Spain; Holland; Philippine Islands; VQ7LO, Kenya Colony, B. E. Africa; JB, South Africa; RV15, Siberia; and PLW, Java.

In India, where a friend and short-wave fan lives, they must have fairly good reception conditions. Although the heat is unbearable, this chap has succeeded in logging, RV59, Russia; Germany; Holland; England; Italy; Spain and France. Naturally the catches that are rare here are easy there. For instance, whenever the following stations are broadcasting he is able to pick them up: Java, VQ7LO, Kenya Colony; JB, South Africa, and SUV, Cairo; VUC, in Calcutta, India, is the only station that transmits programs dedicated to the Mohammedan religion.

ZFS, Nassau, is in communication with WND, Hialeah, Florida, daily from 10 a.m to 6 p.m. ZFS operates on a wavelength of 66.48 meters. This is a government op-  
(Continued on page 46)

MINISTÈRE DES POSTES  
TÉLÉGRAPHES & TÉLÉPHONES

Paris, le *1<sup>er</sup> Juin* 1932

DIRECTION DE LA RADIODIFFUSION  
103 Rue de Grenelle, 103  
PARIS

Monsieur,

J'ai l'honneur de vous accuser réception de votre lettre du *22 février 1932* Je vous remercie des renseignements que vous avez bien voulu me communiquer sur les résultats que vous avez obtenus dans l'écoute du poste d'État de Radiodiffusion Coloniale et en particulier lors de nos transmissions du *22 février 1932*

Nos émissions se font tous les jours sur les longueurs d'onde ci-après : 19 m. 68, 25 m. 20, 25 m. 63.

Veuillez agréer, Monsieur, l'assurance de ma considération très distinguée.

*Le Directeur du Service de la Radiodiffusion,*

กรมไปรษณีย์โทรเลข  
POST & TELEGRAPH DEPARTMENT.  
Bangkok, Siam

วันที่ Date *29<sup>th</sup>* April, 1932

Telegraph Address  
Telepost Bangkok  
No. *R R 137*

Captain H. L. Hall,  
104, West 64 Street,  
New York City,  
U. S. A.

Dear Sir,

I beg to acknowledge receipt of your postcard dated 16th March reporting on your reception of our transmission of HSP on 16.9 metres, and beg to verify that your statement is correct as regards date and time of transmission.

Thanking you for your report and further ones will be appreciated.

Yours faithfully,  
*Anna Uram*  
Superintending Engineer of Radio

TWO MORE VERIES  
At the left, a "very" from "Radio Coloniale," in Paris; above, a verification from HSP, in Bangkok, Siam.

# Short Wave Short Cuts

## Using Tube Bases

THE bases of burned out tubes make ideal forms for plug-in coils. The main trouble is to remove the glass bulb from the "works" inside the base without getting glass spattered all over the house. It is neither as difficult nor necessary to heat the tube to remove the base. Simply wrap the tube in a piece of cloth and hit it a strong blow with a hammer. The bulb will fly off, but the stem and connections will remain. Dig these out with a screw driver, cut the insulation, and blow the holes in the base clean by first heating them in a flame and whipping the base out from you in a quick motion.

When soldering new connections to the pins, use only a special solder on each, and shave off the excess with a knife so that the solder will not stick in the socket.

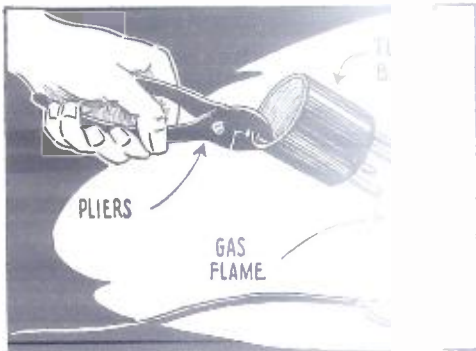

Just heat and whip quick.

## Efficient Lead-in Insulators

THE increasing popularity of doublet antennae using twisted-wire lead-ins has served to emphasize the fact that most amateur fans pay little attention to the method of bringing the lead-ins through the window. A simple arrangement can be snaked through a window, but two wires, whose spacing must be maintained evenly, require a better arrangement.

A very simple, cheap, and efficient lead-in insulator can be made from two ordinary porcelain knobs, which cost only about a dime apiece. Drill a one-inch hole through a board fitted under the window; mount the

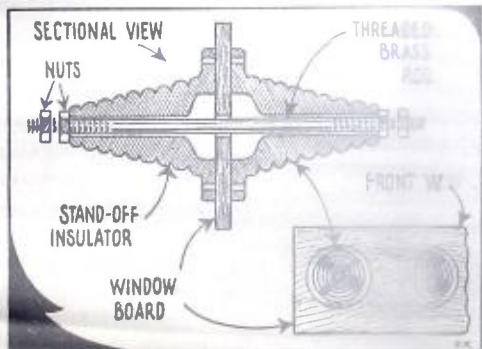

This idea saves many an ohm.

## Money for Your Ideas

Every radio experimenter runs across handy little kinks that save time, trouble, effort, and money. For the best short cut submitted each month, we will pay \$5.00. Other published kinks will be paid for at the rate of \$1.00 each.

Keep your descriptions within 100 or 150 words in length, typewritten or written in ink on one side of the paper. Put your rough sketches on separate sheets, with your full name and address clearly indicated. Mail all contributions to the Short Cut Department, SHORT WAVE RADIO, 1123 Broadway, New York, N. Y.

insulators carefully over the hole, and run a threaded brass rod through, tightening it at both ends with nuts and washers. A pair of insulators of this kind look extremely neat and businesslike, and are just as good as much fancier insulators that have threaded studs, etc.

## Separate B Supply Switch

IN experimenting with receivers, it is frequently necessary to shut off the entire power pack while some slight change is being made in the wiring or a part to avoid the danger of shock or short circuits. With the juice off, the tubes cool down quickly, and then the experimenter has to wait impatiently for them to heat up again when he snaps the switch on.

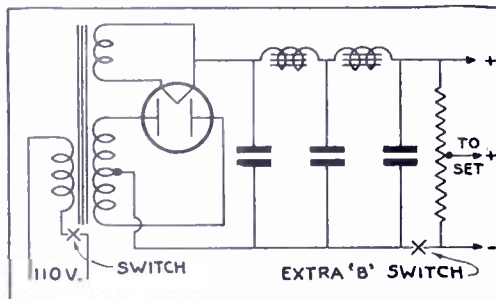

A simple, but effective, scheme.

To facilitate changes of this kind, it is a good idea to install a separate single-pole switch in the B circuit alone, to supplement the 110-volt primary switch. Thus, the filaments may be left on and the plate voltage thrown off, so that the experimenter can put his fingers or tools into the wiring with perfect safety. The best place for the switch is in the B minus circuit to ground.

The same idea can, of course, be applied to battery receivers using heater type tubes.

## Simple Vernier Dial

A plain three- or four-inch round bakelite or composition dial, of the kind that was very popular a few years ago, can easily be converted into a smoothly operating "vernier" dial. Simply arrange a friction driving mechanism against the lower edge. This may consist of a long 6-32 or 8-32 machine screw, at one end of which is a large knurled battery nut, which acts as control knob. Just under this nut is a rubber washer about an inch in diameter (a faucet washer is fine for the purpose), held in place by nuts on both sides. The screw is passed through a hole in the panel and fastened on the back with two nuts, tightly enough to make the rubber washer press against the dial.

A "slow motion" effect is thus obtained. Rough adjustment can be made directly on the dial.

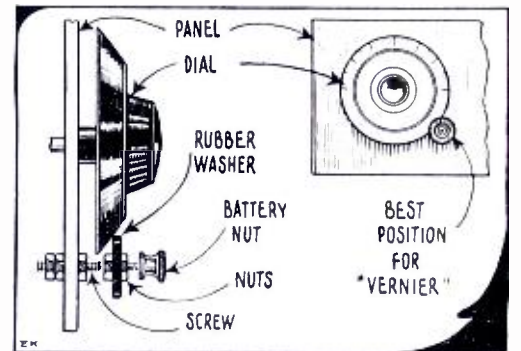

A necessity for S.W. sets.

## R. F. Choke Container

Wooden pill boxes with close fitting covers, which can be purchased for a few cents each in any drug store, make excellent containers for home-made R.F. choke coils. Select several different sizes, to accommodate different chokes.

As the wood is usually somewhat porous, give the boxes a couple of coats of varnish or shellac to prevent them from absorbing moisture. For binding posts, use short 6-32 brass screws and nuts. Mount these on the cover rather than on the box, as it is pretty difficult to get the tip of a soldering iron into a box only an inch or so in diameter. With the choke all connected, you can now close the box permanently with a tiny brad.

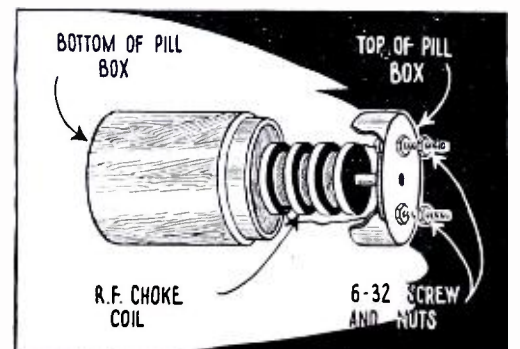

What to do with old pill boxes.

# Building and Operating the CONVERTIBLE 5

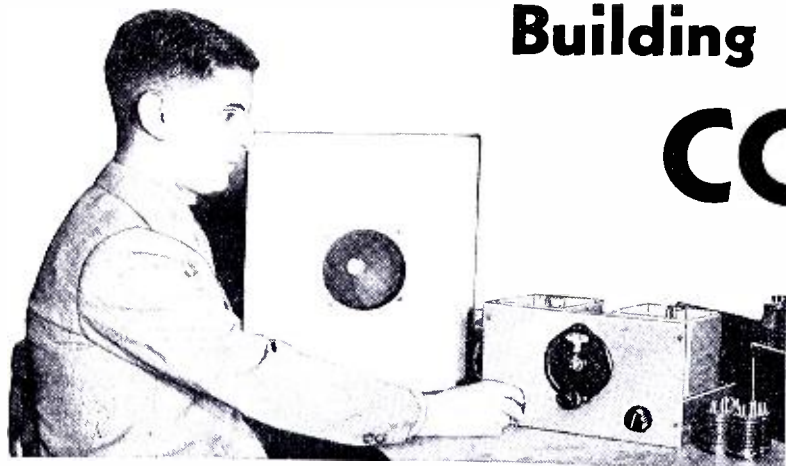

**SUMMARY:** This article treats in detail the construction and operation of a very excellent five-tube receiver. The author is shown to the left tuning this set. See the "log" of stations.

**T**HE "Convertible Five" was designed to meet the demands of numerous radio fans for an effective, easily constructed short-wave receiver using modern tubes in a reliable circuit of proved sensitivity, selectivity, and stability, and having sufficient output for really good loudspeaker operation. Recently there has been an overabundance of very simple one- and two-tube battery-type receivers employing obsolete, though workable, circuits, and these have not appealed particularly to either beginners or the more experienced enthusiasts who want to enjoy such conveniences of 1933 radio as pentode tubes, full A. C. operation, freedom from body detuning effects, and dynamic speaker volume even on European, Asiatic, and Antipodal stations.

As it finally stands, after considerable experimentation with tubes, circuits, and mechanical construction methods, the "Convertible Five" consists of two main units: a tuner-amplifier and a separate power pack. This set was described originally in the *New York Sun*, and proved very popular with short-wave fans in the East.

The receiver proper uses a shallow box-shaped chassis measuring 12 inches long, 9½ inches wide and 2½ inches deep. Against one long edge is a front panel 8 by 12 inches, on which are mounted only a tuning dial, a volume control and a regeneration control. The power pack is a plain inverted box 8½ inches square and 2½ inches deep. Connection between the two units is made by a plug-and-cable arrangement that is very convenient and flexible.

Electrically, the "Convertible Five" comprises one stage of tuned radio-frequency amplification using a type 58 pentode, a regenerative detector stage with another 58, a first audio stage using a type 56 and a powerful output stage using a single type 2A5, which is one of the latest heater-cathode output pentodes. The combination is an excellent one.

The set covers all the active short-wave channels between 200 and 13 meters by means of five pairs of plug-in coils, tuned by a double-section variable condenser having a maximum capacity of 100 mmf.

By Robert Hertzberg

per section. This condenser, as specified in the list of parts, is a specially designed short-wave instrument, having the two rotor as well as the stator sections completely insulated from each other. The rotor movement is 270 degrees, as compared to 180 degrees (half a circle) for ordinary condensers.

A number of different kinds of switching devices with fixed coils were considered in an attempt to eliminate plug-in coils, but the latter proved to be so much more convenient, from both the electrical and mechanical standpoints, that they were retained for the final model of the set. Plug-in coils are not at all the nuisance many people think they are; they are not changed every ten minutes, but perhaps twice during an evening. The change-over takes only about three seconds, anyway. Factory-wound coils are available, but complete winding data are given

## Does "Convertible 5" Work? —This Tells the Story

*A casual half hour of listening before supper netted the builder of the "Convertible Five" three European short-wave stations, only a degree apart on the No. 62 coils, which tune from 23-41 meters. Here is an extract from the log:*

5:45 P. M. Dial 38. Operatic selections. Woman announcer saying "Radio Roma Napoli." Later news items in Italian. Max. vol. too loud for comfort.

6 P. M. Dial 39. Phonograph music. Announcements in German. Clear announcement of "Konigswusterhausen" in German, then similar announcement in English: DJD, 25.51 meters. Vol. control at zero and still quite audible. Vol. control all up, music unbearably loud.

6:15. Dial 40. French political speech. "Radio Coloniale" (outside of Paris). Weak, but understandable.

for the benefit of the many fans who like to "roll their own." The coil forms used are the National six-prong, which are 1½ inches in diameter and 2 inches long. The constructor can wind one pair of coils at a time or wind them all at once, depending upon his pocketbook.

The power pack consists merely of a power transformer with an electrostatic shield between the primary and the secondary (an important feature for short-wave work), an 80 rectifier, one or two 30-henry filter choke coils, and three 8 mf. electrolytic filter condensers. Binding posts are provided on the chassis so that the field winding of a dynamic speaker may be used as part of the filter system and, at the same time, receive its own excitation; if this is done, only one filter choke is required. If the constructor happens to have a dynamic speaker with a built-in field supply, the second choke will be needed. A special 110-volt outlet is mounted on the power pack chassis; this is connected in parallel with the power transformer primary and is controlled by the same switch that turns the set on and off. With the power cord of the dynamic speaker with its own field supply plugged into this outlet, the set owner need never worry about leaving the field current on accidentally after turning off the receiver itself. This is a small, but not an unimportant, point; many a good speaker runs for days sometimes because of lack of just such a common switching scheme.

The power pack is built separately from the receiver for several good reasons: first, a separation of three or four feet between the heavy units of the power pack and the highly sensitive receiver circuit is very beneficial, as far as overall quietness and stability are concerned; second, many radio fans, particularly those former broadcast set constructors who are now finding the short waves a new source of interest, have perfectly good power packs or parts for them that they can use without trouble, whereas they probably have none of the new short-wave parts needed for the receiver; third, once a power pack is built, it is rarely shifted around very much, whereas



the receiver will undoubtedly be the subject of considerable experimenting. If the heavy, iron-filled power transformer and chokes were part of the receiver chassis, the instrument would be exceedingly difficult to handle.

The extreme flexibility of the receiver in all these regards is the basis for its name. No cabinet is used, as the restless experimenter will only find this a nuisance when he decides to try a different grid leak or by-pass condenser. Besides, the inside of the set looks more interesting than the outside, and the builder will have occasion to show it off when he entertains visitors with foreign programs, picked up direct on the short waves.

The drilling layouts are based on the use of original parts used in the model illustrated. Substitutions may be made at the discretion of the builder; but the ratings in regard to such important things as coils, condensers and shielding should be followed if disappointment is to be avoided.

While the parts for the "Convertible Five" are not particularly cheap, neither are they very expensive. The aim of the designer has been to produce a good set of medium cost, rather than a "low priced" set. There are already a number of acceptable cheap sets; the "Convertible Five" is for the man who wants something better in the way of both equipment and results.

### Making the Set Chassis

The drilling and bending of the main base and the shield cans of the "Convertible Five" represents the major portion of the mechanical work on the set, and should be done slowly and carefully. The following tools are required: hand (or power) drill, scriber, center punch, hammer, flat, rattail, and half-round files, three small "C" clamps (the 10-cent kind are O.K.), dividers, an accurate machinist's square, pliers, hacksaw, small cold chisel and small tinner's snips.

As long as the aluminum is cut perfectly square, little difficulty will be experienced in laying out the holes accurately with the square. Start with the  $17\frac{1}{4} \times 14\frac{3}{4}$  inch piece, put it in front of you, and study the drilling layout. It is a good idea to unwrap all the parts and identify them before making a single mark on the aluminum. Practically all of the small fixed resistors and condensers are supported by their own connecting wires and can be forgotten temporarily.

The double tuning condenser fits along the short center line. The end of its shaft does not go through the front panel, but is about  $\frac{3}{4}$  inch away from the front end of the chassis after the latter is bent. On the front leaf are R1 and R4. (It will be convenient to refer to the parts by their numbers, as given in the complete list of parts.) On either

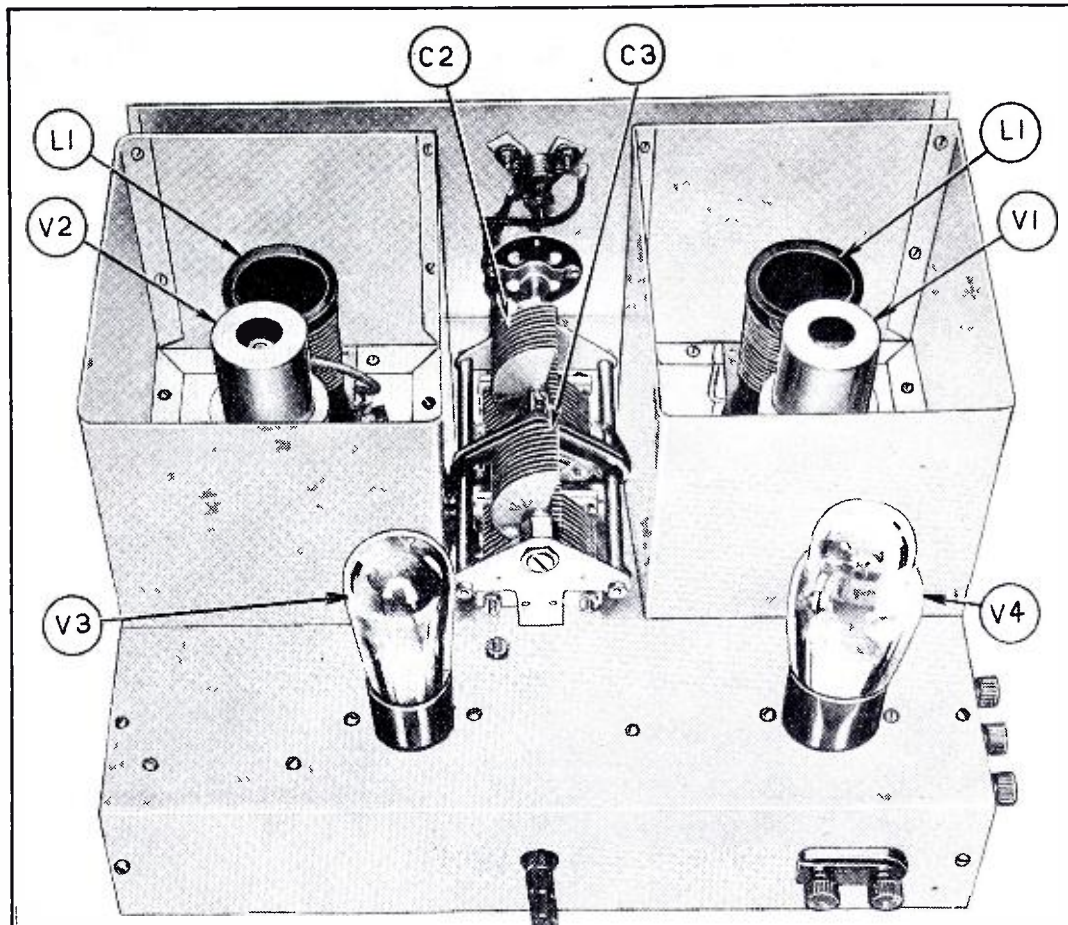

PHOTOGRAPH OF THE TOP DECK OF THE "CONVERTIBLE 5"

The location of the tubes, tuning condensers, coils, binding-post strips, etc., are easily found from this photograph.

side of the condenser is a tube socket, the latter nearer the front. The coil receptacle is equipped with four feet; the extra holes in the same cluster are for passing wires through the aluminum. The same screws that hold the six-prong sockets for V1 and V2 also hold the round tube shields. The tube socket for V3 is behind and slightly to the left of V2; the socket for V4 is almost directly behind V1.

On the left leaf are mounted antenna trimmer C1 (in a position between V1 and the first coil socket), and to the rear, the triple binding-post strip for aerial and ground connections. On the right leaf are the power switch SW and the earphone jack J. The latter must be insulated from the aluminum and is therefore mounted on two one-inch-square bits of bakelite, with the stud carefully centered to avoid contact with the chassis. A little friction tape wrapped around the jack stud will help matters.

Neither C1 nor SW are mounted on the front panel—their usual place—because they require only occasional adjustment and there is no sense in having them clutter up the panel. The phone jack, usually put on the back of most sets, is much easier to reach in its position on the right side. The convenience of this arrangement will be appreciated later by the builder.

On the back edge of the chassis is merely the double binding-post strip for the loudspeaker. The flexible cable emerges through a large hole in the center of this leaf. The parts mounted by the screws on the under

side of the chassis are T1, in the extreme right corner behind V1; R9, held by one screw of C2-C3 and another screw behind the latter, and T2, between the sockets of V3 and V4.

All holes not otherwise marked are made to pass 6/32 screws; a No. 27 drill is just right. To make the socket holes, first drill out a circle of No. 27 holes slightly smaller in diameter than the required hole. Break out the disc with the chisel and smooth off the hole to the correct diameter with the half-round file. This sounds like a lot of labor, but the operation is surprisingly simple.

To make the various other large holes, start with the largest drill the chuck will take (usually  $\frac{3}{16}$  inch with hand drills), ream it a bit with the tang of the flat file enough to get the rat-tail file in, and the rest is easy.

Of course, all holes should be marked with a center punch. Clamp the aluminum flat on a solid table, with a few old boards underneath to take the drill when it comes through, and everything will go smoothly. To allow the round files free play, slide the aluminum off the edge of the table, retighten the clamps, and proceed. The builder is advised to use the files carefully, as they eat away the soft metal very quickly.

After drilling holes for each part, test the fit by mounting the latter temporarily. A little reaming here and there may be necessary to make up for slight inaccuracies in drilling. Drill the socket holes for V1 and V2 first, as these will be covered by the shield bases later and any misstrokes

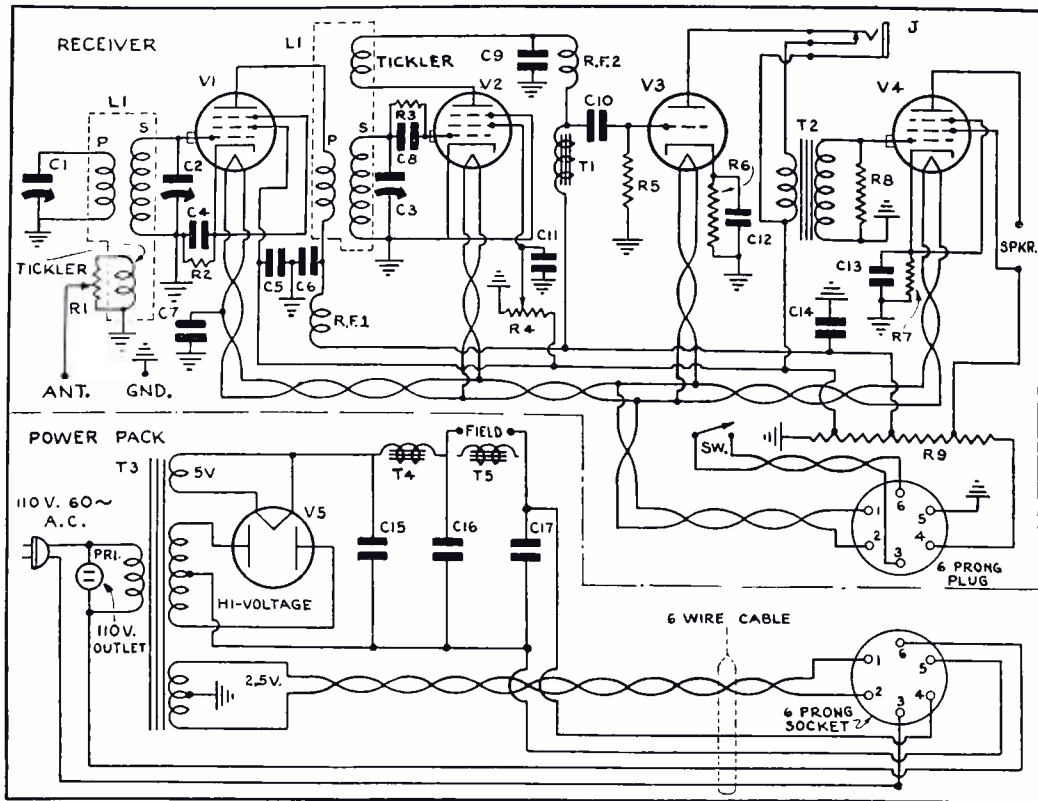

SCHEMATIC CIRCUIT OF THE "CONVERTIBLE 5" AND ITS POWER UNIT

Choke T5 is not required if the field of the speaker is used as a choke.

#### RESISTORS

- R1—2,000-ohm potentiometer (Electrad Super Tonatrol No. 553).
- R2—300 ohms, 5 watt (Trutest—Wholesale Radio Service Co.).
- R3—5 megohms, 1 watt (Lynch).
- R4—50,000-ohm potentiometer (Electrad Super Tonatrol No. 557).
- R5—250,000 ohms, 1 watt (Trutest).
- R6—2,000 ohms, 5 watt (Trutest).
- R7—400 ohms, 5 watts (Electrad).
- R8—250,000 ohms, 1 watt (Trutest).
- R9—15,000 ohms, 50 watts, wire wound, with 3 movable taps (Electrad).

#### CONDENSERS

- C1—20 mmf. midget (Hammarlund).
- C2, C3—Double section variable, 100 mmf. per section (National type SE-100).
- C4, C5, C6—.01 mf. mica (Solar).
- C7—.05 mf. 500 volts electrolytic (Trutest).
- C8—.0001 mf. mica (Solar).
- C9—.00025 mf. mica (Solar).
- C10—.01 mf. mica (Solar).
- C11—2 mf., 500 volts electrolytic (Trutest).
- C12—5 mf., 35 volts electrolytic (Trutest).
- C13—25 mf., 50 volts electrolytic (Trutest).
- C14—2 mf., 500 volts electrolytic (Trutest).
- C15, C16, C17—8 mf., 550 volts electrolytic.
- RF1, RF2—2.5 millihenry R. F. chokes (National).
- T1—300 henry impedance (Trutest).
- T2—Audio transformer, not more than 3:1 ratio (Trutest).
- T3—Power transformer, with low and high voltage windings for 80 rectifier, and 2.5 volt filament winding (Trutest).
- T4—30 henry, 100 ohm filter choke (Tru-

test).

- T5—Same as T4, but optional.
- L1, L1—Pairs of plug-in coils, six prong forms, wave ranges as follows: 13-25, 23-41, 40-70, 65-115, 115-200 meters. Home made as per specifications to be given, or National coils Nos. 61, 62, 63, 64 and 65.

2—Special six-prong sockets for plug-in coils (National).

Wafer sockets, one each for following tubes: 58, 58, 56, 2A5, 80 (Eby).

2—Tube shields for 58's (Trutest).

1—Illuminated vernier dial (National type B).

J—Single, open circuit jack (Pilot).

Sw—Snap switch for 110 volts.

2—Double binding post strips (Eby).

1—Triple binding post strip (Eby).

1—Insulated universal coupling (Hammar-

lund).

1—Piece 1/4 inch brass rod, 1 1/4 inches long.

1—8 wire battery cable.

1—6 prong connector plug (Alden).

1—6 prong receptable, wafer type (Eby).

Tubes: Two 58's V1, V2; one 56, V3; one 2A5, V4; one 80, V5 (Sylvania).

1—Dynamic speaker, 1,000 ohm field, input transformer to match one 2A5 (Magnavox or Trutest).

Aluminum for receiver chassis: one piece No. 14 gauge, 8 by 12 inches, for front panel; one piece No. 14 gauge, 17 1/4 by 14 1/4 inches, for rear base; two pieces No. 20 gauge, each 21 by 5 3/4 inches, for shield cans. For power pack, one piece No. 14 gauge, 13 1/2 by 13 1/2 inches.

1—50 ft. roll No. 18 solid tinned hook up wire, push-back insulation type.

1—Power cord, twisted flexible pair, as long as desired, with plug at end.

1—Female receptacle.

of the file won't show. With these holes as experience, the holes for V2 and V3, which are more exposed in the back, will come out better.

Don't make any holes yet for the two shield cans that enclose V1 and coil L1 on the left, and V2 and the other coil, L1, on the right. (Note: all these directions as to left and right are given with the understanding that the edge containing the two potentiometers, R1 and R4, is near-

est the constructor.)

The bending operation requires the C clamps and a couple of length of 1 1/2 x 1 1/2 or 2 x 4 wood blocks. Saw out the corners of the sheet as marked and score the aluminum heavily along the dotted lines that run from corner to corner. Do this on both sides of the sheet. Cut one piece of wood 11 7/8 inches long and clamp it carefully along one edge of the aluminum (top face to the

table). Slide the sheet over the edge of the table so that the whole 2 5/8-inch leaf overhangs. Start bending upward by leaning heavily on the aluminum with your hands, and then complete the operation with repeated blows of the hammer. The aluminum will not come perfectly at right angles, but don't worry about it, as you can readily press it into shape later to form a satisfactorily even box.

Repeat the operation with the other long edge, then cut the wood to 9 3/8 inches and repeat with the short sides. If a sufficiently heavy table is not available, use the cellar stairs or any other firmly anchored flat support. The completed chassis will be astonishingly rigid.

The front panel is simple. Place it up against the front edge of the chassis and scratch through the holes for R1 and R4 from the inside of the latter. Also spot the center hole for the dial by sliding the insulated universal coupling over the condenser shaft, with the short piece of brass rod in the other end of the coupling. With this center hole as a starting point, drill the dial mounting holes with the aid of the handy full-sized template found in the box. It is advisable to handle the front panel in this manner, rather than to drill it all up beforehand, as the bending of the chassis will make accurate register very difficult otherwise.

The two shield cans are identical. Drill the holes first, cut the little notches along the edge, and bend with the aid of the wood block. Bend up the half-inch mounting lips with a pair of flat-nose pliers before closing in the overlapping edges with two small machine screws. The 20-gauge aluminum will seem like paper after the constructor has bent the chassis.

There are still no holes in the chassis for the shields. Spot these through the holes in the feet after centering the shields carefully around the coil and tube sockets. The long outside edges will come flush with the outside edges of the chassis; the front edges about 7/8 inch from the front panel.

Lastly, cut a 1/2-inch-wide slot a 1/2 inch high in the bottom edges of both cans facing the tuning condenser, directly opposite the terminals of each section of the latter. These are to pass connection wires inside the shields. After testing the fit of the shields, lay them aside, as they will not be mounted permanently until the receiver is completely wired.

All parts are mounted with small machine screws and nuts. Mount the sockets for V1 and V2 with the large filament holes to the left of the chassis; V3 socket with the filament holes to the back, and V4 socket with the large holes to the right. Examine the coil sockets and you will notice two pairs of three holes, one group of holes closer together than the other. Mount one socket, to the left of the condenser, for antenna

coil L1, with the close group pointing to the front panel; the other socket, for the detector coil, to the right of the condenser with the close group pointing to the right. These positions are important as an aid to the shortest and most direct wiring.

The grid leak and grid condenser (C8, R3) are mounted upright between the detector coil socket and the detector tube V2 by a small L-shaped bracket, with a flexible lead running from the top connections to the cap of the type 58 detector.

The front panel is held in place by the fastening nuts of R1 and R4 and the lower dial screw. This is plenty of support. The short piece of 1/4-inch brass rod is fastened in the dial stud and connects with the variable condenser shaft by means of the flexible coupling. This arrangement is much simpler than attempting to make the condenser shaft slide accurately into the dial.

The shafts on the potentiometers, as furnished by the manufacturer, are too long. Cut them short enough to accommodate any small knobs that strike your fancy.

Finish the assembly work by mounting C1 and the triple binding-posts trip on the left side of the chassis, the double b.p. strip on the back, the switch and the phone jack on the right side, and T1, T2 and R9 on the underside. The voltage divider resistor, R9, will fit off at an angle to clear transformer T2. Incidentally, obtain two extra sliding contact bands for this resistor, so that you can adjust the various plate voltages properly.

Note: The detector plate coupling impedance, T1, the grid coupling condenser, C10, and the grid leak, R5, may be obtained in the form of a single case unit, made by National.

### The Power Pack

The base of the power pack used with the "Convertible Five" is a simple inverted box of aluminum, drilled and bent as shown in the accompanying drawing. The same instructions as to handling the flat sheet of aluminum given for the receiver proper apply to the pack.

Of the two holes on the left side (see pattern), the upper is for a flush-mounting 110-volt outlet and the lower for a six-prong socket. In mounting the latter, turn it so that the two large (filament) holes are nearest the inside edge of the chassis. The large rectangular hole is for the power transformer.

Drill out a series of holes inside the border of this opening, break out the center piece with a cold chisel and file the edges smooth with a flat file. Test the fit of the transformer carefully and be particularly certain that none of the terminal lugs or wires touch the metal. Mount the transformer with the 5-volt and high-voltage secondaries facing toward the socket for the 80 rectifier tube, which is just to the right. Place this socket with the filament

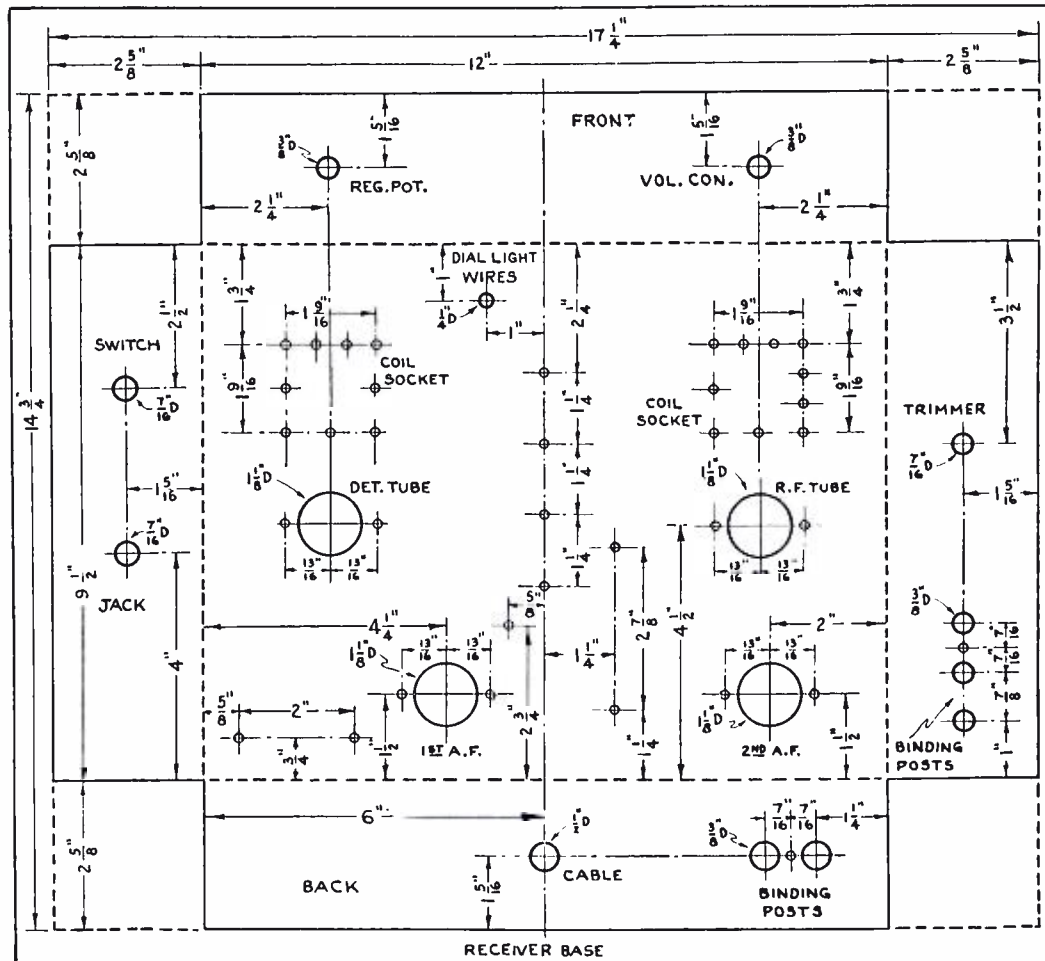

DRILLING LAYOUT OF THE CHASSIS OF THE "CONVERTIBLE 5"  
Note particularly that the front leaf is shown to the rear on this drawing.

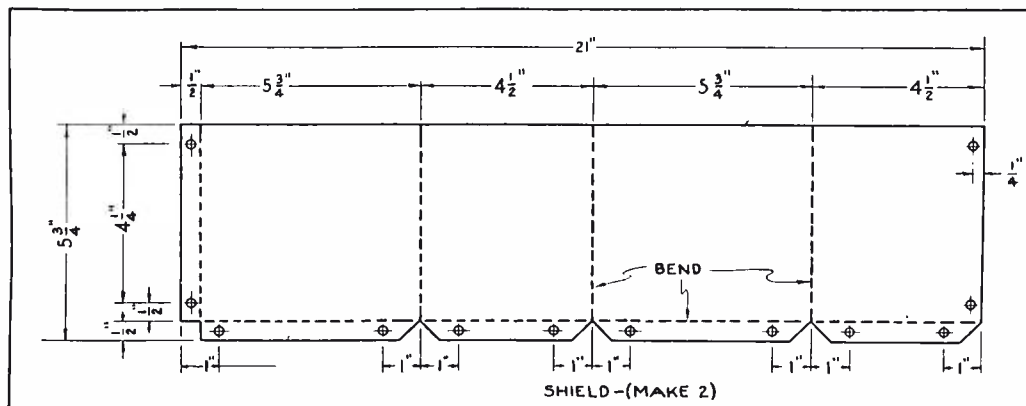

COMPLETE DRILLING LAYOUT OF THE SHIELD CANS

holes facing the side of the chassis that has the single large hole for the power cord.

If these directions as to position are followed, the wiring will fall in its logical place and the leads will be short and direct.

The three holes along the right edge are for the 8 mf. electrolytic filter condensers, which mount in an upright position by their own large fastening nuts. The small holes along the bottom are screw holes for the 30-henry filter chokes. Below them are holes for a double binding-post strip.

At this point it might be well to interrupt the assembly instructions to say a few words about the loudspeaker, as this has an important bearing on the filter system of the power pack. If you have an old but perfectly good dynamic speaker with built-in field supply (thousands of such speakers were sold during recent years), you can eliminate the binding-post strip and use two 30-henry chokes. Plug the speaker

power cord into the 110-volt socket on the pack, short out any switch already in the cord of the speaker, and you will then control the speaker's field supply simultaneously with the power pack itself by means of the snap switch on the right side of the Convertible Five.

If you intend to buy a new speaker, get one with a field having a resistance of not more than 1,000 ohms. Use only one 30-henry filter choke and by means of the double binding-post strip connect the field so that it is in series with the choke and thus acts as a choke itself, at the same time that it is receiving its own field excitation.

In either case, the speaker must be fitted with an input transformer suitable for a single 2A5 output tube. A transformer intended for push-pull 45's will work very nicely if only the two outside terminals of the primary are used, with the center-tap idle.

It is advisable to install the 110-volt outlet on the power pack chassis

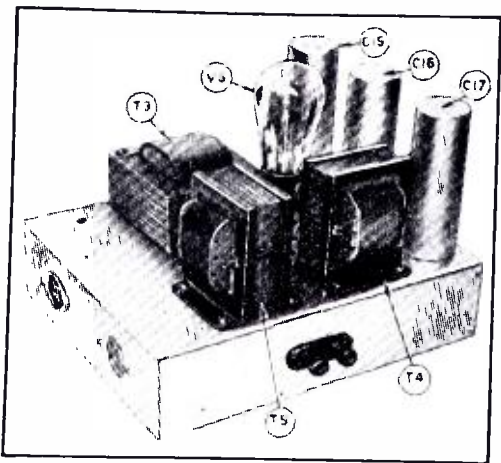

VIEW OF THE TOP OF THE POWER PACK

The lettering, of course, corresponds to that given in the list of parts.

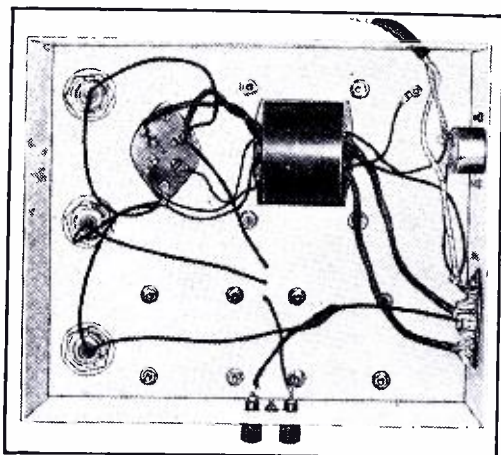

UNDERVIEW OF THE POWER PACK

Note how coil of the power transformer protrudes through the cutout.

even if the second loudspeaker arrangement is employed; the device costs only about 15 cents and it will prove very useful in experimental work.

### Wiring the Set

With all the drilling, bending and mounting of parts done, the wiring is next. Start on the receiver chassis, with the shield cans still not mounted. Identify all the socket terminals (the tube manufacturers are again including little socket diagrams in the packing boxes. Providence be praised!) and wire all the filaments in parallel, twisting the No. 18 wire between sockets. Also run a pair of dial-light wires from the socket of the detector tube, V2. Push the eight-wire cable through the hole in the back and select any two pairs of wires for the filament supply. Parallel two wires to form a single connector. This is done to prevent voltage drop through the cable; if only one pair of wires were used, there would be an appreciable loss, as the leads in practically all such cables are only No. 18, and this is not heavy enough. Identify the other ends of the same wire and solder them immediately to the two large prongs of the six-prong plug. The eight-wire cable thus acts really only as a six-wire cord.

Select another pair of wires and run these to the snap switch. The remaining pair is for B plus and B minus. It makes no difference as to

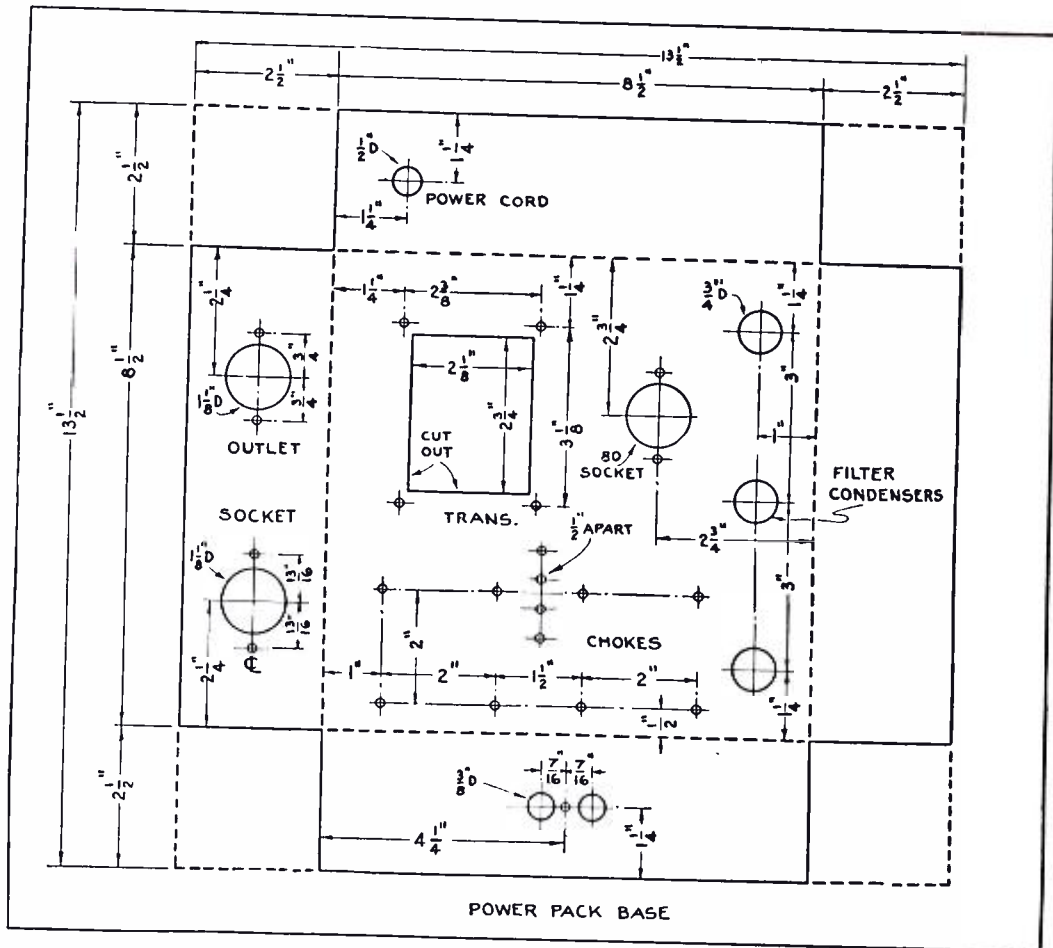

COMPLETE DRILLING LAYOUT FOR THE POWER PACK OF THE "CONVERTIBLE 5"

The holes labeled "outlet" are used for mounting a female receptacle in case the speaker is of the a.c. type. These drilling layouts are suitable only if the constructor uses the major parts specified by the author. Complete mounting data for the power pack are obtained by referring to the two photographs at the left and the drilling layout shown above.

what color lead you select for any of these connections, as long as you keep track of them carefully and follow them through the six-prong plug to the correct terminals of the six-prong socket on the power pack.

The B plus lead goes to the rear end of the divider resistor R9; the other end of the latter (nearest the dial) is grounded directly to the aluminum.

Face the three terminals of the volume and regeneration potentiometers R1 and R4 toward the side of the set bearing the trimmer condenser C1. Ground the terminals nearest the inside surface of the chassis and both controls will then operate correctly, *i.e.*, volume and regeneration will increase with clockwise rotation of the knobs.

Bypass condensers C4 and C5 may be mounted by the same screws that hold the socket for V1, C6 by one of the detector stage coil socket screws, and C9 by one of the socket screws of V2. The grid condenser and leak (C8-R3) are mounted upright on the top side of the chassis, between the detector tube socket and the detector plug-in coil socket, by means of a little L-shaped bracket. All the other fixed condensers and resistors in the set are soldered directly between points in the circuit by their own lugs or connecting wires.

It is necessary to have at least one pair of plug-in coils at this stage in order to wire the coil sockets properly. The No. 63 coils, which tune from 40 to 70 meters, are recom-

mended, as these are the most useful coils anyway. Trace the leads carefully. The heavy winding is the secondary. The upper end is the grid end, the lower the ground end. Interwound with this winding is a coil of thinner wire, which acts as a primary for the coil plugged in the detector (right-hand) compartment; the upper end goes to the plate of the first tube, V1, the lower to the r.f. choke and B plus 180 volts. This same winding on the coil used in the antenna stage (left can) is merely shunted by the trimmer condenser C1 and acts as a small absorption loop.

### Tickler Wound in Slot

In a slot at the bottom of each coil is a small winding of a few turns. This is the tickler of the detector coil and the primary of the antenna stage coil. Note that the two coils of any numbered pair are absolutely identical and are freely interchangeable between the antenna and detector stage coil sockets; the two smaller windings merely serve different functions in the respective positions.

Special note: The detector will oscillate with the tickler coil connected only in one way. If you don't hit the correct "poling" the first time, simply reverse the connections to the tickler terminals of the coil socket and the set will come to life immediately.

From the standpoint of circuit stability it is important to use a

single "ground" point for the common ground connections in the antenna and detector stages. One each of the socket mounting screws of the type 58 tubes is the most convenient point.

Connections between the caps on the type 58 tubes V1 and V2, the tuning condenser C2, and grid condenser C8 are made by short lengths of flexible wire, with grid clips on their ends. Be sure to allow enough wire to clear the edges of the tube shields.

Starting with the tube V1 and the antenna coil socket, the wiring runs over to the right to the detector stage, makes a U turn, and follows along the back edge of the chassis, where the audio components are located. Although these detailed suggestions sound complicated, the work becomes very obvious and simple if it is done slowly section by section. Errors are invariably due to impatience on the part of the builder. Take your time; the little details of assembly and wiring are what make the job interesting.

After the knobs have been put on the potentiometers and the trimmer condenser, and the dial has been set to read 0 with the condenser plates unmeshed, and 150 with them fully meshed, the very last step is to mount the shield cans with short screws.

The wiring of the power pack is very simple. Between the 2.5-volt filament terminals of the power transformer and the filament lugs of the six-prong socket use double pairs of No. 18 for the reason already mentioned in connection with the power pack. Ground the B minus connection (prong No. 5 as marked in the diagram).

In order to obtain satisfactory single-dial tuning with the "Convertible Five," it is necessary that the pairs of plug-in coils for the various wavelength ranges be wound carefully and accurately. The writer recommends the factory-made coils very highly, as the wire on them is laid in lathe-cut grooves in the forms and will remain firmly in place. However, if the builder is careful and patient, he can readily wind his own coils, using blank 1½-inch forms.

Each coil contains a primary of heavy wire (winding No. 1) and interwound primary (No. 2) and a tickler (No. 3). Two identical coils are required for each wave range. Observe the direction of winding very carefully. The following table gives the details of each set of coils:

No. 61 (National number):

13.5 to 25 meters.

No. 1—6¼ turns No. 14 enameled wire, spaced 7/32 inch.

No. 2—5¾ turns No. 24 enameled wire.

No. 3—2 turns No. 26 s.s.c. wire.

No. 62 coils—23 to 41 meters:

No. 1—11¾ turns No. 18 enameled, spaced 5/32 inch.

No. 2—9¾ turns No. 24 enameled.

No. 3—2 turns No. 26.

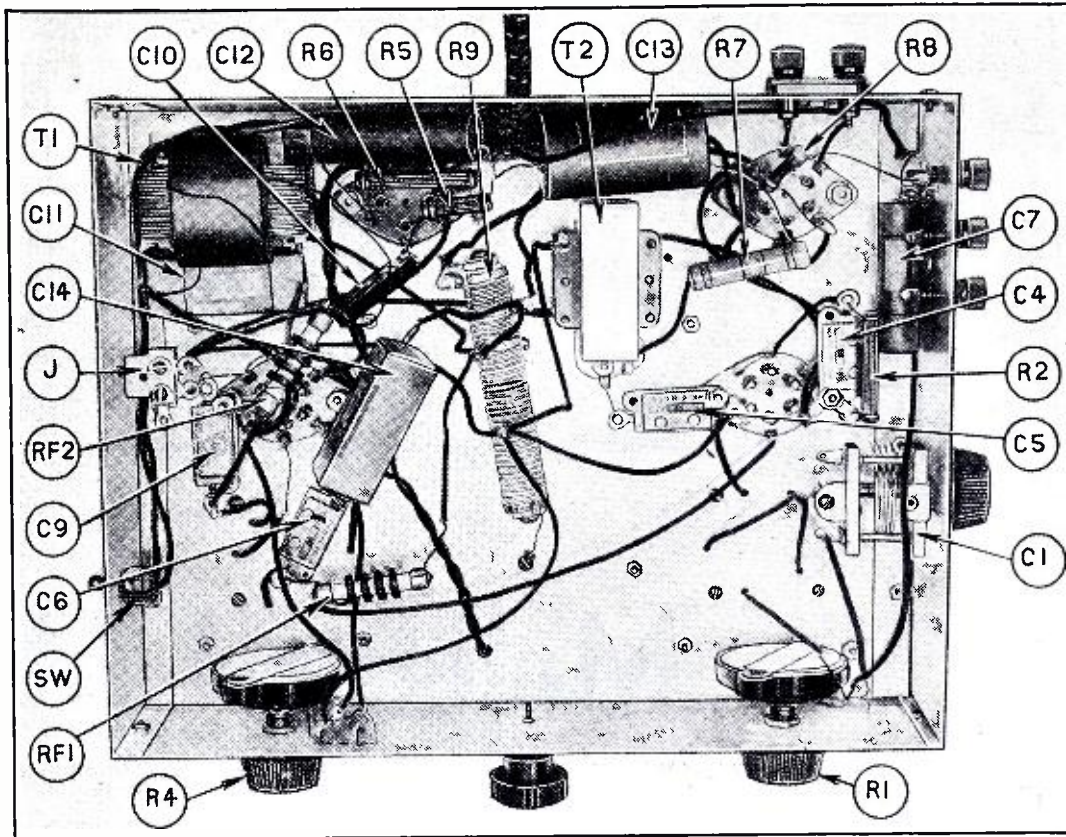

UNDERVIEW SHOWING PARTS LOCATION OF THE "CONVERTIBLE 5"

The reference letters here, as in all other drawings in this article, correspond to the list of parts.

No. 53 coils—40 to 70 meters:

No. 1—19¾ turns No. 18 enameled, spaced 3/32 inch.

No. 2—12¾ turns No. 26.

No. 3—2 turns No. 26.

No. 64 coils—65 to 115 meters:

No. 1—34¾ turns No. 24 enameled, spaced 1/16 inch.

No. 2—21 turns No. 26.

No. 3—3 turns No. 26.

No. 65 coils—115 to 200 meters:

No. 1—62¾ turns No. 24 enameled, spaced 1/32 inch.

No. 2—38 turns No. 26.

No. 3—5 turns No. 26.

In all cases the No. 3 winding fits in the small slot at the bottom of the coil form. The No. 1 winding starts about 3/8 inch above the slot with all coils except the No. 65's, on which it must start quite close in order that all the wire will fit. The No. 2 winding in all cases is wound between the turns of No. 1 after the latter has been put on. Do the No. 3 winding first, as this is easiest; then follow with No. 1 and then No. 2. Pull the wire very tight and you will have no trouble with it shifting later.

The best way to handle the coils is to clamp the spool of wire to a firm support and to unwind a three-foot length, the end of which is threaded through the proper hole in the form and soldered to the right prong. Tie the spool so that it can't unravel. Holding the form in both hands, walk slowly toward the spool as you slowly force the form onto the wire.

The correct adjustment of the sliding taps on the output divider resistor on the underside of the "Convertible Five" chassis is a matter of great importance. The slider nearest the "hot" end (the one running to the B plus lead of the power pack)

must be moved down until it reads between 260 and 275 volts on a high-resistance voltmeter. This is fed to the 2A5 output tube. The next tap, which feeds the plates of the r.f. and detector tubes, must read 180 volts. The third tap, which feeds the r.f. and detector screens and the first audio plate, must deliver 75 or 80 volts.

These adjustments must be made while the set is actually running. Let the set warm up thoroughly before applying the voltmeter, as the readings for five or eight seconds after the switch is snapped on will be very high. Be careful about touching the chassis while fooling with this resistor; 250 volts kicks plenty! Once the resistor has been adjusted, it can be forgotten.

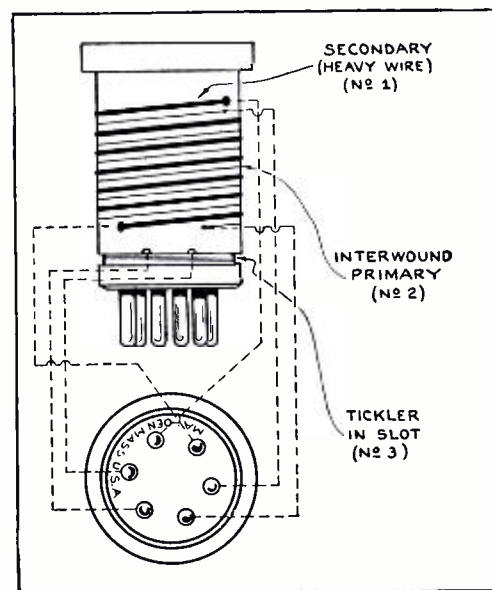

WINDING DETAIL OF THE PLUG-IN COILS

The connections between the terminals of the windings and the prongs are shown here.

By Robert S. Kruse

Illustrations by the Author

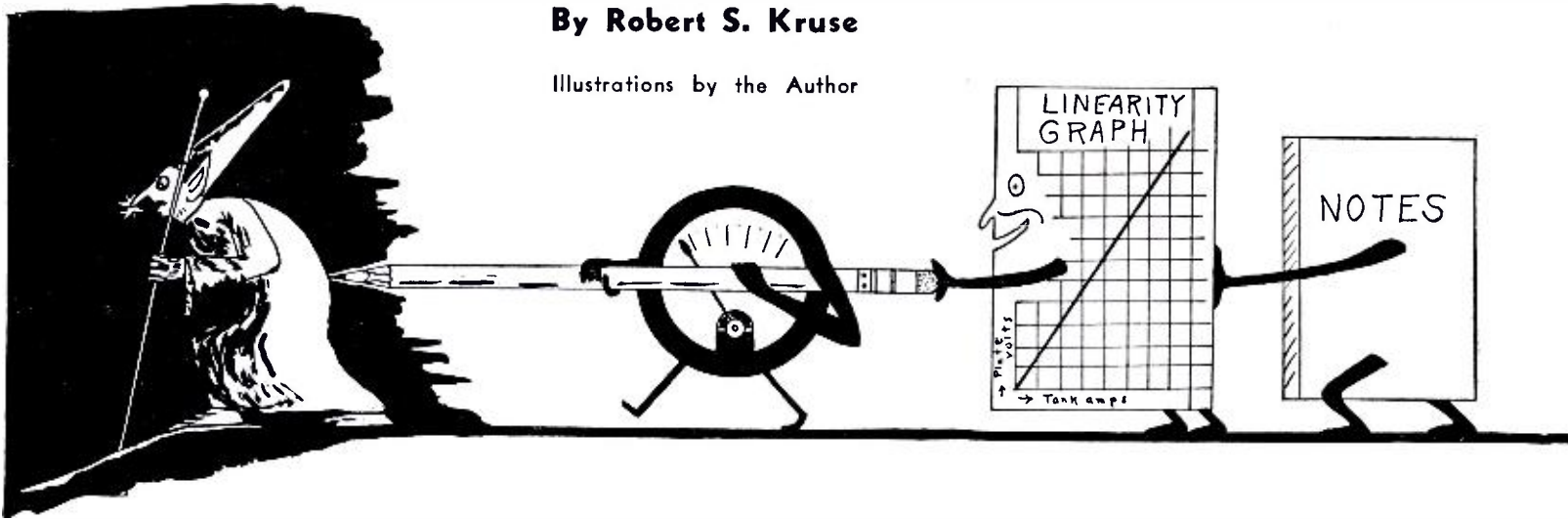

# The Maligned Modulator

**SUMMARY:** "Your modulation sounds overmodulated, Old Man; I suggest you look over that modulator stage," quoth the Wise One. But, declareth Kruse—

**W**ITCHES cause no fear today, black cats are taken up by the S. P. C. A., crowds walk carelessly under ladders, and business continues on Friday the 13th. Superstition is bankrupt, and black magic remains only in a few families which inherit the ability to understand New England road markings and the timetables of the Pennsylvania Railroad. This is an age of *fact*.

And yet, in the 80-meter amateur phone band there reside today Masters of Darkness, come straight from the gloom of antiquity, to whom there is neither distance, nor fact, nor any rule of physics. These wizards have but to *listen* to an amateur radio station at a distance in order to tell instantly what ails that station and to pass down Solomonic judgment—thus:

"Your modulation isn't very good, Old Man. Better fix up that modulator."

## A Little Debunking

Nonsense and rubbish! I deny that anyone can listen to a station in the yowling bedlam that is the principal amateur phone band and can learn anything which warrants him to publicly denounce a station. How can he discount selective fading? How can he discount stray noises? How can he discount noises in his own receiver? How can he discount the distortions in his \$3.67 loudspeaker? And finally, how can he judge one station in the swarming, crowding, ephemera-dance on the amateur voice bands? The answer is simple—he cannot.

He belongs with the other side-show freaks, the fortune tellers, the



The Listening Wizard at work. Note the utter confidence with which he diagnoses your case!

peddlers of crazy patent medicines, and the purveyors of Assyrian lucky rings. In short—you needn't believe him at all.

## Where Fact Resides

If you wish to find out what is actually true, you must cut out such uncertainties and look at the transmitting equipment from *nearby*—measuring and testing. If the results of those tests tell you nothing, they will be useful in the hands of a more experienced person who *can* interpret them. This can be done—in fact, I often do it.

No, I am *not* an ether-wizard; for my guessing is done deliberately in the presence of the figures and diagrams which the operator took directly from his apparatus—and *my*

results will be checked back by him in the same way.

## A Shortcut or Two

Now after one has worked over enough stations, a certain ability to guess ahead must, of course, develop; for some things keep happening again and again—at one voice station after another.

So today I am able to start out by thinking, "The trouble probably isn't in the modulator," and generally that is right. Almost always the trouble is somewhere else, in any one of so many places that one could write a book about it—as indeed I have! Lets look over a few of them.

There seems to be an astonishing percentage of stations which have a perfectly good speech system fed by a "phooey" microphone in a room full of echoes and noises. Maybe the mike was good originally and has been dropped, or fed too much battery current—or is just plainly worn out. Recollect that broadcast stations that still use carbon mikes get them repaired very frequently, also that they *pay* for a good one. The machinery of all carbon mikes is pretty much alike; what you pay for in a mike is almost entirely the fidelity, which is a *direct product of care in manufacture*. Home-made mikes are pretty uniformly terrible—no matter what sort they are—carbon, condenser, or dynamic.

As for the room, what would you think of a broadcast station that tried to use a plain room for a studio, or that tried to sneak out of room effects by cutting down the amplifier gain and then hissing and spitting confidentially into the mike?

Well— (Continued on page 43)

# Why Skip Distances?

**SUMMARY:** One of the biggest stumbling blocks in short waves is the phenomenon of skip distances. Signals seem to travel along nicely for a while, and then suddenly disappear, only to show up again a few thousand miles away. Why? When? How? you ask. We have consolidated most of the authentic information and are reproducing it below. The article is fundamental, and is designed specifically for the beginner, although many an old timer will do well to refresh his memory by reading this article. Questions concerning skip distances are welcome, and will be answered to the best of our ability.

**P**ROBABLY the best reason that accounts for the intense interest in the short-waves is that great distances are spanned with a very small amount of apparatus. True, this reception requires a greater amount of skill than the broadcast set; and also reception is not nearly as uniform as regular broadcast reception, but it sort of "makes the cheese more binding."

The erratic behavior of short waves first received the attention of Marconi. Following his published reports, a great number of experimenters started investigations, until finally, enough data were collected to enable engineers and scientists to know the peculiarities of short waves. They found that short-wave signals were weaker closer to the transmitter than at great distances from it, in some cases; they found a marked difference in the intensity of received signals at night as compared to the daytime; they also found that the variations were seasonal as well as diurnal. On top of all this, the conditions vary according to the transmitted frequency.

Short-wave listeners are familiar with the peculiar reception conditions; in fact, erratic reception has become so commonplace that it may hardly be considered a detrimental factor. The theory explaining the

action of short waves is extremely interesting, and should be understood by all short-wave listeners.

Before stating the theory of short-wave propagation, it might be well to list briefly the characteristics of the short-wave bands commonly used today:

## Characteristics of Short Waves

*Frequencies between 10 kc. and about 2300 kc. (30,000 — 130 meters):* Signals lying within this band follow a very definite law and include, of course, the regular broadcast channels, from 500 to 1500 kc. The absorption, technically called "attenuation," of these signals, is very well known, and is familiar to almost every user of a radio set.

*Frequencies above 3000 kc. (below 100 meters):* These are especially suitable for long distance communication (especially in the daytime). The strength of these signals rapidly increases with frequency instead of decreasing, as would be expected.

*Frequencies above 6000 kc. (below 50 meters):* At about this frequency a peculiar effect known as "skip-distance" manifests itself. It is found, for instance, that a signal from a given transmitter is heard at a certain point. It is also found

that the same signal from the same transmitter is also heard at another point which is much farther from the transmitter than the first reception point. Furthermore, the signal cannot be heard between these two points. From an elementary standpoint, the signal sort of skips over the surface of the earth between the first point of reception and the second point of reception. This phenomenon is called *skip-distance effect*. It is known that the actual skip-distance, in miles, is much greater in the winter than in the summer.

Although very great distances may be covered with very short waves, there appears to be a *limiting frequency* beyond which long-distance communication is impossible. In other words, long-distance communication becomes more feasible as the frequency increases, and then, at a certain frequency, called the *limiting frequency*, it falls off.

To account for these peculiar effects, Kennelly in this country and Heaviside in England suggested the possibility of the existence of an ionized layer at some distance above the surface of the earth. From the properties of such a layer, they found that a signal originating from a transmitting antenna could be reflected from the layer, just like a

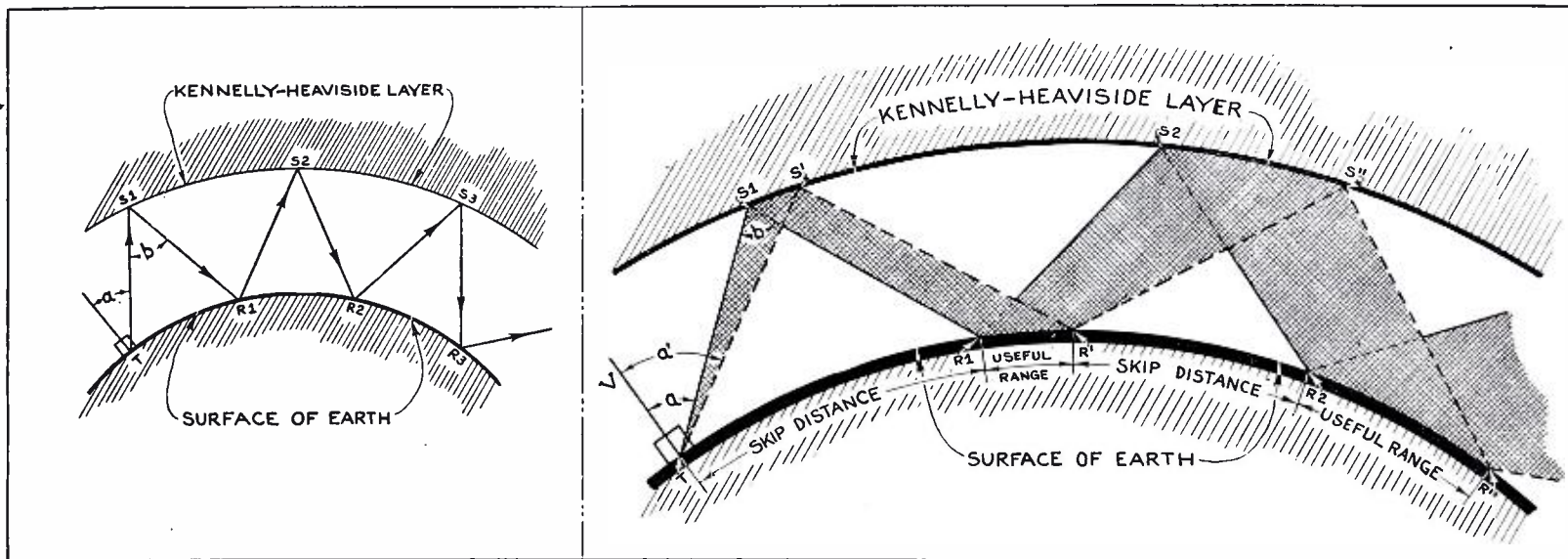

FIG. 1, LEFT; FIG. 2, RIGHT: ILLUSTRATIONS SHOWING THE IDEA OF REFLECTIONS AND ZONES OF RECEPTION.





VT, that is our solid line, may not be returned to the earth at all! It is clear, therefore, that with a fixed layer, the frequency of the signal and the angle it makes with the vertical determines the skip distance. This is the same as saying that for any given frequency there is a limiting angle of uptake from the transmitting antenna above which radiation is no longer useful because it penetrates the layer and does not return to earth. Now, as the frequency is increased and the rays become more penetrating and less easily deviated, they have to strike the layer at flatter and flatter angles in order to return to earth, and therefore, as the frequency is increased, the rays which angle sharply upward are eliminated as far as useful communication is concerned, leaving only the very low-angle rays of any use.

If the frequency of our signal were then further increased, penetration would become so great that nothing would come down at all, and hence we have our *limiting frequency* beyond which reception at great distances is impossible. These low-angled rays, when they do return to earth, return at very great distances from T, so that long-distance communication is very easy.

Perhaps it would be best to explain a little more fully what is meant by "zones of reception." To do this, let us refer again to Fig. 2. Our transmitter is located at point T and is sending out a constant signal of a fixed, high frequency. Let us also suppose that the solid line in this figure represents the most vertical ray from the transmitter which returns to earth, and the dotted line, the most horizontal ray of the transmitter which returns to earth. All the rays, then, included between these two extremities represent the useful rays suitable for communication. Any receiver there-

fore, located between R1 and R1' will receive the signal. The distance between T and R1 represents the skip distance. In some cases, there is a region between R1 and R1' in which reception is not feasible. This region is called the secondary skip-distance region. Occasional instances of tertiary skip distances have also been found.

If the effective height and density of the Kennelly-Heaviside layer is altered, the whole picture changes. If the layer is higher and less dense in electrons, conditions will be essentially the same, except that the limiting frequency will be lowered somewhat; thus, even at moderate frequencies, secondary skip zones may open up at night and, as is well known, critical frequencies (frequencies beyond which rays are not returned to earth) are much lower at night than they are in the daytime. The ideal conditions, of course, exist when the first zone of reception overlaps the second zone, which in turn, overlaps the third zone in order that there may be no missing regions intervening other than the first skip distance zone.

There are marked seasonal variations in those paths which pass through those regions of the earth's surface which are subject to wide differences in climate from summer to winter. This is particularly true in paths that pass close to the polar regions. During the summer, the polar regions are exposed to long periods of sunlight, and the presumption is that the production of electrons is at a high rate. Thus, higher frequency signals are reflected more easily, and are, therefore, more suitable for communication purposes. During the polar night, however, the situation is reversed. The electron density is smaller, making it necessary to use much lower frequencies than can be

used in the summer time. It is not possible to use the low frequencies necessary in the winter time for summer communication because of the high absorption in the summer, so that for constant reception conditions in the polar regions, it is necessary to change the frequency to correspond with the season.

Of course, it is only possible here to state briefly what may or may not happen in general at different frequencies in the short-wave band. To assist listeners in securing best results from their receivers, we are reproducing here a chart which gives the skip distance day and night for winter and summer, the maximum reliable range day and night for winter and summer for different frequencies corresponding to wave lengths from 10 to 200 meters. The services for which the various frequencies are intended are also stated, as well as important remarks.

There is only one point of explanation needed in interpreting this chart. The third column, "range of ground wave," has not as yet been explained. A transmitting antenna radiates in all directions, similar to the radiations of light from an ordinary electric bulb. Some of these rays travel parallel to the ground for very short distances and are called "ground waves," while the remaining travel into space toward the Kennelly - Heaviside layer. The ground wave is rapidly absorbed by the surface of the earth and by objects on the surface of the earth, and so soon disappears. Therefore, it is not very useful on short wavelengths. The sky waves are those we have been discussing in this article. In concluding, it might be instructive to mention that although the sky wave is the important one in short-wave work, the ground wave predominates in the regular broadcast band.

## Stations of the U. S. S. R.

**B**ECAUSE of the peculiar reception conditions on the short waves, many foreign stations cannot be received with good volume; furthermore, when they are received, you sometimes lose the announcement, because invariably the station fades at the crucial moment! This is particularly true of stations in the U. S. S. R. (Russia).

Capt. H. L. Hall has carefully collected the data listed to the right for the readers of SHORT WAVE RADIO. Keep this list in front of you when listening; and while the station is announcing, glance through the list if you expect the station to be in the U. S. S. R. The association of the announcer's voice and the written name may clinch the call or city in which the station is located, and may make the difference between identifying the station or not.

If any readers have compiled a similar list, send it in.

## Radio Centre, Solyana 12, Moscow: U. S. S. R.

### List of Main Radio Stations

	Wavelength	KW.	Freq.
Leningrad RV70 .....	349	100	857
Kharkov RV20 .....	369	10	815
Odessa RV13.....	450	10	667
Moscow — Experimental.....	720	20	417
Sverdlovsk RV5.....	825	50	364
Leningrad .....	857	100	350
Moscow-Stalin .....	1000	100	300
Kiev RV9 .....	1035	36	290
Tiflis .....	1071	10	280
Minsk RV10.....	1105	35	271
Moscow-Popov .....	1117	40	269
Moscow—Trade Union.....	1304	100	230
Novosibirsk .....	1380	100	217
Moscow-Comintern .....	1481	500	202
Moscow, Central House of the Army	45.38	10	6610
Moscow, Trade Union Station....	50	20	6000
Moscow, Politechnical Museum....	77.52	0.15	
Khabarovsk .....	70.2	20	
Petropavlosk Kamschatka.....	60	0.5	

# Satisfactory Short-Wave Reception

**SUMMARY:** *At best, any short-wave receiver can only reproduce in proportion to what is applied to it by the antenna. As a consequence, the antenna becomes the most important item in a radio installation aside from the receiver, and, therefore, should be given much more consideration than is given at present.*

*Mr. Lynch tells the story here, in the first installment of a series of articles on antennas. To illustrate his point, Mr. Lynch has given us illustrations of a typically good antenna installation. The photograph to the right, for instance, is the aerial used by Capt. H. L. Hall, whose article on foreign stations appears in this issue. Completely shielded on one side by an eighteen-story apartment building, one would think that the location is a "dud." But such is far from the case. In fact, Capt. Hall attributes much of his success to a good antenna installation.*

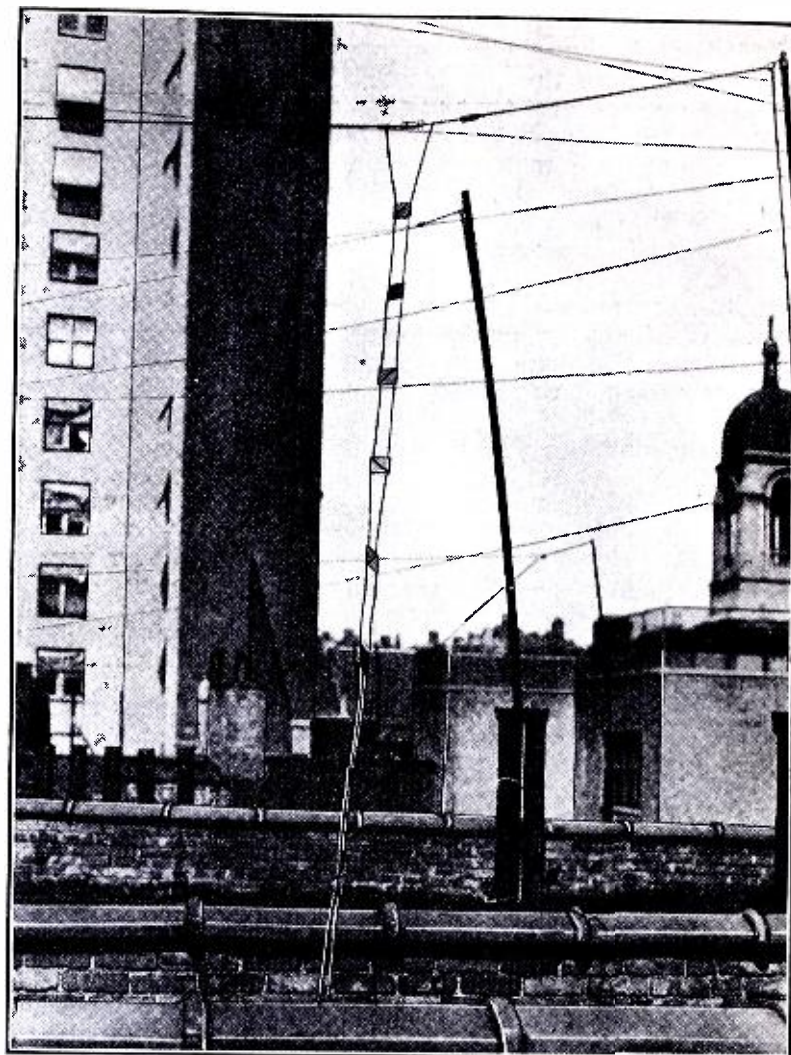

**G**UY LOMBARDO, Lowell Thomas, S. S. Van Dine, and many other important personages are coming to realize the importance of short-wave broadcasting to our every-day lives. Doctors, dentists, lawyers, brokers, and every business man who has an interest in foreign countries, are looking for information concerning developments in them by a direct short-wave contact between their broadcasting stations and their own homes, in addition to the usual sources of information such as the newspapers and magazines.

Naturally, with an entirely new system of communication—and short waves are practically new to the man in the street although they have been used consistently and with increasing satisfaction by radio engineers for a number of years—it has been most unfortunate that their application to broadcasting has been accompanied by the introduction of some very unsatisfactory types of radio receivers. That was done in an attempt to cash in rapidly on this important and very popular field.

The introduction of so-called converters and short-wave adapters, designed to operate with the ordinary broadcast receiver, has caused no end of trouble. Some of these devices are, in themselves, highly satisfactory, but in most cases their application has not been carried on intelligently. The result has been that short-wave broadcast reception has not compared favorably with the very fine results people are in the

habit of hearing on the regular broadcast waves. In many instances, short-wave programs from foreign countries have been accompanied by so much interference and so-called "background noise" that we have frequently heard the expression, "If this is a sample of what you get on short waves, I am perfectly willing to leave them completely alone."

It is not surprising to find such an attitude assumed by the man in the street; but it is not only surprising, but depressing, to find that a similar viewpoint was adopted a short time ago by some of our most important engineers. In fact, the engineers of one very important company analyzed this situation very completely, and the company went so far as to put their findings into a small booklet, which enjoyed rather wide circulation. This booklet would lead the reader to believe that it is practically impossible to secure any satisfactory programs on the short waves. It suggested that it was entirely possible to secure broadcasting from the foreign stations, but that this broadcasting was accompanied by so much interference and so much undesirable racket that there was practically no use in securing it.

It is granted, that with an adequate short-wave system, results of the nature described in that booklet were very likely to be secured, and that the conclusion of any normal person would be a decision to leave short-wave broadcasting alone. More than an ordinary amount of harm

was done by this book because the man in the street is usually perfectly willing to accept a negative decision from engineers, when he can assume that the engineers themselves would prefer to issue a rather glowing report, so that additional sales may be made.

## The Truth

There is no question whatever, that there are some locations in which it is a practical impossibility to secure satisfactory short-wave broadcast reception. However, such places are so few and far between in comparison to the number of good locations, that they need not be given consideration in any general treatment of the subject. In nearly every case of heavy background interference on short waves, a suitable antenna system does the trick.

Many retail stores in our large cities, where interference from subways, trolley cars, automobiles, doctors' and dentists' establishments, beauty parlors and the like is very bad, have found it entirely possible to secure very satisfactory short-wave reception—reception which compares very favorably with modern broadcast reproduction—by taking certain simple, inexpensive precautions. Information of a contrary nature is incorrect, detrimental to the radio industry at large, and most misleading. Apparently the information contained in the booklet to which we have referred was obtained by engineers more familiar with

mathematics and slide rules than with modern short-wave receiving systems. My own first reactions to short-wave broadcasting were negative. I was not inclined to listen to radio hash for hours on a stretch with the slight possibility of hearing a satisfactory reproduction of an English jazz band. So I determined to do something about it.

As a result of my writings on this subject, appearing in various radio publications, I receive many letters from owners of radio receiving equipment in all parts of the world. Some of these letters indicate that very satisfactory results are being secured in all parts of the world on short waves, with equipment which requires little or no engineering knowledge, and by people who know nothing more about short-wave reception than the average person knows about his broadcast receiver and the manner in which it functions.

Up to about three years ago, Captain Horace L. Hall, who retired from a life-time at sea to engage in the pursuit of making miniature replicas of all types of marine craft, found that he could work better at night than during the daytime. This led him to the belief that he might be interested in listening to short-wave programs while he was working, because most of the regular broadcasting in this country was already off the air by that time.

The portion of New York City in which he lives is just about the center of Manhattan Island; and if there is any place in the world where interference could be bad, that should be it. Within the past three years, Captain Hall has received verifications from nearly every short-wave broadcasting station in the world. The receiver he uses is one of the older type National receivers, called an SW-5. It was designed two or three years ago, and it is still delivering entirely satisfactory results.

The accompanying list will give you some idea of what Capt. Hall has been hearing. A short time ago, to check for myself upon the very glowing statements he was making concerning the manner in which he receives programs from abroad, I visited his home. I can say that none of the statements he has made is exaggerated, and I know that his experience is now being duplicated by an increasing number of short-wave enthusiasts.

One frequently hears of a one- or two-tube receiver, operated by a farmer boy in Iowa, a priest in China, or some Amazon explorer, that brings in stations all over the world on short waves. Some of the glowing press stories regarding these accomplishments have been greatly exaggerated. On the other hand, some perfectly remarkable results have been secured with comparatively simple apparatus, where practically no precaution has been taken to assure the best results. These results can be duplicated, even



By

Arthur H. Lynch

### Editor's Note

*It is doubtful if any one individual has done more to popularize short-wave broadcast reception than the author of the present informative article. Mr. Arthur H. Lynch is known to many readers as the former editor of RADIO BROADCAST, and Editorial Director of the Mackinnon-Fly Publications, which included RADIO NEWS, SCIENCE AND INVENTION, and twelve other publications.*

*As the editor of the former publication Mr. Lynch was first to sponsor the superheterodyne, the short-wave adapter, and automobile radio for popular use. He inaugurated and conducted the famous International Radio Broadcast Tests, in 1923-4 and 5.*

*While editing RADIO NEWS, he started an active campaign for auto radio and was the first to predict the present market. He called a meeting of all radio manufacturers at the Advertising Club of New York and told them just what could be expected in the auto-radio field.*

*Mr. Lynch was among the first to realize that short-wave broadcast reception would get nowhere if it was accompanied by the usual interference. The introduction of his antenna systems has made satisfactory short-wave reception possible in many poor locations.*

*Next month, Mr. Lynch will have an article for us on "Various Means of Coupling Transposed Transmission-Lines to All Classes of Receiver."*

under the most adverse circumstances, in nine cases out of ten, by the application of common sense.

Short-wave receivers of all types are now available which, when coupled to a suitable antenna system, will enable the user to secure satisfaction. Whether they be superheterodynes, regenerative receivers, tuned radio-frequency receivers, or what not, really makes but little difference. With short-wave radio, as with most other types of radio, you get about what you pay for. If you want the best results, you will have the best type of receiving equipment. And it is equally true that the best need not be the most expensive. However, in order to get satisfactory results with any type of receiver, it has been found necessary to use a suitable antenna system. As a matter of fact, it has been the improvement in the design of antennas and the realization for the need of these antennas that has made the rapid advance in short-wave broadcasting possible.

In connection with antennas, there has been so much misinformation published and the entire matter has been complicated by so much engineering verbiage that the person who attempts to use short waves is frightened by the mass of mathematics and the apparent complexities the installation of such a system would involve.

Hundreds of letters have crossed my desk in the past few months inquiring as to this and that formula for the erection of a suitable antenna. People ask whether the doublet is better than the single wire, whether the cage doublet is better than the single-wire doublet, whether the transposed transmission line has any effect on the wavelengths which one desires to receive, and so on, *ad infinitum*.

There is really nothing complex about the erection of a suitable antenna. For most practical purposes, the accompanying diagram will give all the information necessary for any group of various circumstances.

For reception in the United States, of most of the European and Australian stations, an antenna suitable for reception on 50 meters will give the best results. Such an antenna will also be a satisfactory resonator at 25 meters. Since most of the important foreign broadcasters operate on approximately 25 and 50 meters, the single wire doublet antenna shown in the accompanying diagram will work out in a perfectly satisfactory manner. This antenna is extremely simple to erect and its application will give perfectly satisfactory results in nine cases out of ten.

Preferably, this antenna should run in a North-East, South-West direction, resulting in the best reception from stations in a North-East and South-West direction. Little or no attention need be paid to mathematical formulas, most of which has been developed by transmitting en-

gineers for application to transmitters and receivers functioning on a single definite wavelength for communication purposes. Most information of that nature is of little or no use to the broadcast enthusiast who desires to receive on a number of different wavelengths.

For most satisfactory results, regardless of the wavelengths on which you desire to receive, an open transposed transmission-line, made according to the directions given in the accompanying sketch, will give you greatest freedom from local interference and provide greatest response from foreign broadcast stations. The length of the transmission line will make no practical difference in your reception. It may run from a few feet to a few hundred feet in length. One of the stations operated by the American Radio News Corporation in Cuba uses a transposed transmission-line more than 1,500 feet long. Up in Alaska, we know of another such line more than a mile and a quarter long. There is plenty of signal and great freedom from noise at the business end of a suitable antenna system, regardless of the length of the transposed transmission-line.

Some confusion still exists regarding the amount of interference a transposed transmission line will eliminate from short-wave reception. Correspondents frequently tell me that they are troubled by auto ignition noises, especially on waves of about 17 meters. They ask whether my doublet antenna and transposed transmission line will cure this trouble. The answer is yes and no. Not too assuring, is it? Well, here's the reason.

Forgetting all about the lead-in (transmission-line) and considering the antenna, whether of the doublet or any other type, we know that any variation in voltage at the antenna means a signal in the receiver. The incoming radio waves cause such changes, and so do the waves pro-

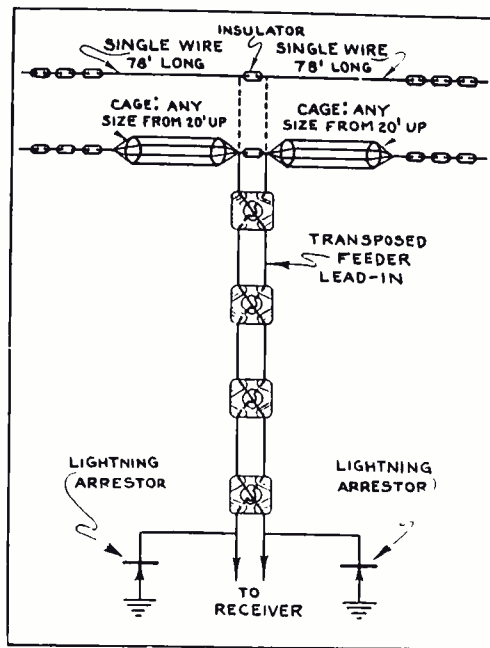

A TRANPOSED ANTENNA SYSTEM

duced by auto ignition systems, or any other sources of interference for that matter. If the voltage set up in the antenna by the auto is as strong as the voltage set up by the desired signal, we are bound to have interference. We can transpose our transmission line until we're black in the face and we can add all sorts of "eliminators" and "filters" and we won't get rid of the interference.

But, fortunately, there is usually a way out. Then, too, it is fortunate for us that waves sent out by autos do not travel as far as regular radio waves. They are also rather limited in the height they reach. Ignition radiation from most cars spreads out from the sides, and is not strong in the front, rear or above the car.

The list to the right is a sample of the log of Capt. Hall, whose antenna is pictured in this article and diagrammed above. Capt. Hall believes that a good antenna is half the job—and we certainly agree with him.

## Stations Heard by Capt. Hall

GAS	England	I2RO	Italy
GAW	"	IAC	"
GSG	"	CNR	Morocco
GSF	"	OCY	Denmark
G5SW	"	PCV	Holland
GBW	"	PHI	"
GBB	"	PDV	"
GBC	"	PDK	"
GBU	"	XEW	Mexico
GSA	"	XDA	"
GSE	"	XETE	"
GSC	"	CMCI	Cuba
GSB	"	OPM	Belgium
GCB	"		Congo
GDS	"	OCI	Peru
G6RX	"	XGM	China
		NRH	Costa-Rica
DJB	Germany	LSX	Argentina
DIQ	"	LSN	"
DJA	"	PLE	Java
DAN	"	PMC	"
DJD	"	PMN	"
DJA	"	FYA	France
DJC	"	FTE	"
		FTA	"
VRT	Bermuda	ZLW	New Zealand
EAR58	Canary Is.	HVJ	Vatican City
HJ3ABF	Colombia	VQ7LO	Kenya Colony
HKD	"	EAQ	Spain
HKO	"	PRBA	Brazil
HKM	"	PSH	"
HJB	"	RV59	Russia
HJ3ABD	"	SR1	Poland
HJ4ABB	"	HSP	Siam
HJ5ABD	"	SUZ	Egypt
HJ4ABE	"	SUV	"
VE9JR	Canada	J1AA	Japan
VE9GW	"	KDK	Hawaii
VE9DR	"	CT3AQ	Madeira
VE9CI	"	HLB	Switzerland
VE9GR	"	HBJ	"
CGA	"	HBP	"
VK2ME	Australia	VE9BJ	Nova Scotia
VK3NE	"	VE9HX	"
VLK	"	VWY	India
PKP	Sumatra	RV15	Siberia
HRB	Honduras	TFU	Iceland
LGB	Norway	YV1BC	Venezuela
PRBA	Ecuador	YV3BC	"
HCJB	"	YV11BMO	"
F3ICD	Indo-China	YVR	"
FZS	"	JB	Johannesburg
CT1AA	Portugal	ZTJ	"

## Notice to Contributors

AS many contributors are aware, it is one thing to send in a contribution to a magazine and quite another thing to have that contribution accepted. An editor's desk is littered with ideas and suggestions that have possibilities and should be worked up; but if a prospective contributor has something to send in, his idea should be worked up completely before mailing.

A word or two about manuscripts: (1) use one side of the paper only; (2) write or, preferably, type all material and double- or triple-space everything; (3) all illustrations should be on separate sheets, each drawing on its own sheet; (4) use pencil sketches only, as we redraw all diagrams, anyhow; (5) all photographs should be 8x10, glossy—small snapshots are usually worthless unless they are clear and you

send in the negatives.

Be prepared to send the apparatus to us for test. In certain cases, the editors must have the equipment on hand for either test or illustrative purposes, and a prospective contributor must be in a position to be able to send in the equipment.

And now, most important of all, the nature of material suitable for this magazine: look over this and subsequent issues carefully. Read the style, note the punctuation and paragraphing, the method of preparation, and the style of the illustrations. Then make your manuscript as close to ours as possible.

Individuality is an important factor in a story in a literary magazine, but in any technical discussion the facts come first and the innuendos second. We do not expect

masterpieces of English literature, but we do expect clear-cut, concise explanations that are readily understandable.

As for payment—an important question in these days—we pay promptly upon publication of the issue in which the article appears. The rate of payment depends entirely upon the nature of the article, the manner of preparation, etc. The length of the article is not the important factor involved: a short kink may contain more information than twenty typewritten pages. Catch on?

Another thing—be sure that material you send in has not appeared in other magazines. We have a complete file of many, many radio magazines here, so that if we should, perchance, catch you cribbing, well—

# Bringing the S. W. Receiver Up to Date

**SUMMARY:** Of the thousands of short-wave receivers now in use, many use 01A's, 22's, 12A's and 71A's. The receivers using these tubes served their purpose in the past, but are

now obsolete. It is the purpose of this and other articles to follow to show exactly what must be done to bring these old sets up to date with the least expenditure of time and money.

**W**HEN a man says that he has a three-tube receiver using 01A's, 12A's, etc., the first question that enters the mind of the experimenter is, "What circuit do you use?" After fully describing the circuit in minute detail,—which discussion usually includes added refinements or so-called tricky details—suggestions for improvements are made, and we have the beginning of a long conference which may last all night and which usually leads nowhere.

It is our purpose here to show

what can be done with old battery sets in order to bring them up to par; in so doing, we are perfectly aware that there are oodles of variations of one- and two-tube sets; we are also aware of the fact that when we tell you how to modernize one type of old receiver, the details are not exactly the same as for the set you have. It is always so. To describe how to modernize each and every variation of two- and three-tube receiver would require volumes and volumes, since there are probably more variations of simple re-

ceivers with a given number of tubes than there are hairs on a cat.

We are fortunate in one respect: by far the majority of simple receivers have many things in common; in fact, there are so many things in common that this article is possible. For instance: the majority of short-wave sets use capacity control of regeneration; they almost all use a conventional antenna coil—only a small number use doublets—and last but not least, transformer coupling between detector and audio prevails. In the sets to be described, the original and modernized diagrams will be given.

## Two Tubes Using 01A's

One of the most popular sets a few years ago was the original *Junk Box* receiver designed by our own Robert Hertzberg. The receiver is extremely simple: it uses two tubes, both 01A's, in a conventional, time-tested circuit. See Fig. 1. There have been no great advances in circuit design since this set was developed; to obtain better reception, all that can be done is to install more modern tubes—tubes that are designed to deliver greater signals.

**2-volt operation:** This famous circuit may be easily redesigned to accommodate the new tubes. The first tube may be replaced by a 32, and the audio tube by a 33; the result is a receiver as modern as possible at this writing.

The revised diagram is shown in Fig. 2. The first thing to do is to replace the four-prong socket used with the audio 01A with a five-prong socket; the same socket may be used with the 32 as was used with the first tube—the 01A—before. Thus, only one new socket is required. The connections to the first tube socket remain the same substantially; the former control grid is now the screen connection, while the grid leak and grid condenser connect to the cap on the top of the 32 tube. Next, remove the audio transformer, and in place of its primary insert a 100,000-ohm resistor (100,000 is the same as .1 megohm, or meg.); in place of its secondary, insert a .5 megohm resistor. Then connect the junction of the r.f. choke and

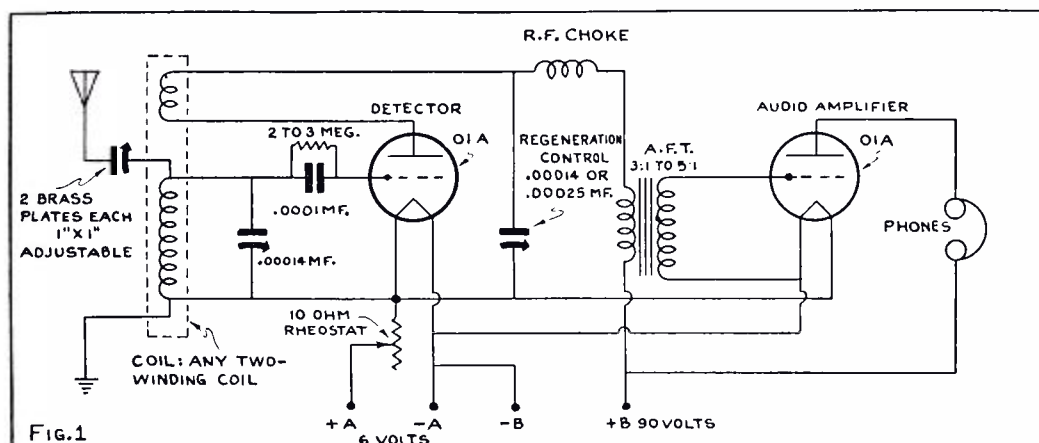

FIG. 1

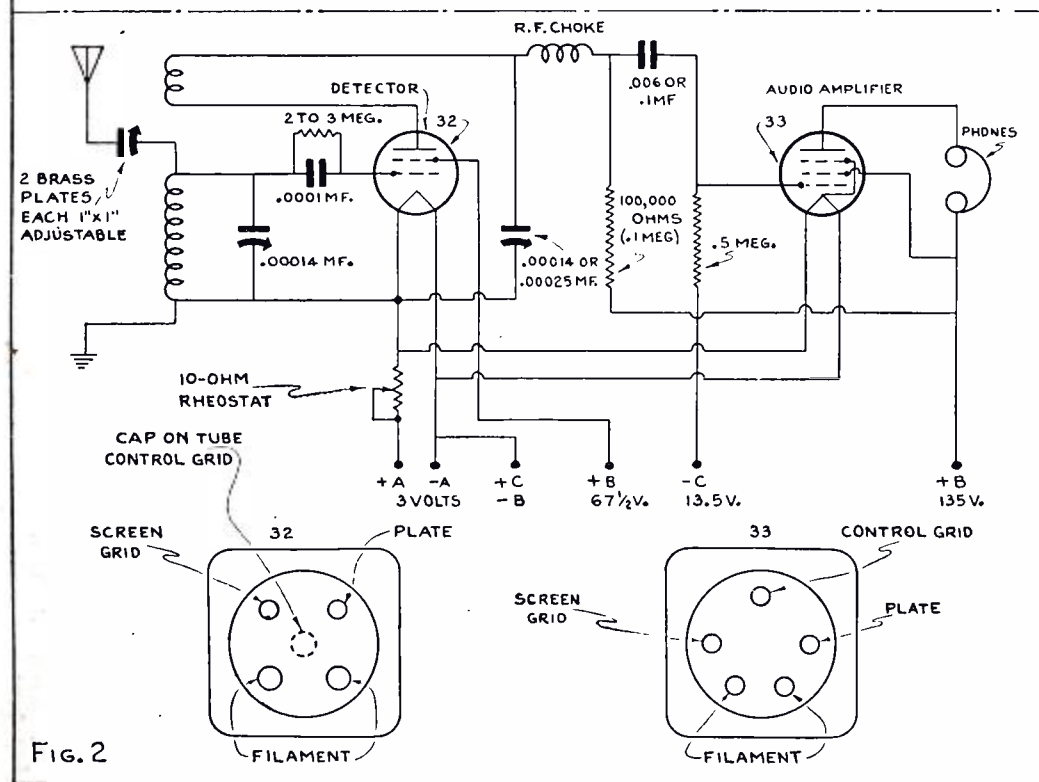

FIG. 2

THE TWO-TUBE 01A SET—BEFORE AND AFTER  
Substituting a 32 and a 33 for the 01A's makes a big difference.

the .1 meg. resistor to the grid of the 33 through a fixed condenser which may have any value between .006 and .1 mf. The 10-ohm rheostat is retained. Connect the screen grid of the 32 to 67.5 volts and the screen of the 33 to the B plus side of the phones. Finally, connect the various C leads, finish the few connections to the socket of the 33, and the job is finished. For convenience, the socket connections of the 32 and 33 are given in the insert of Fig. 2.

Note that the original circuit of Fig. 1 used no C bias on the audio stage. This point was not overlooked in the original design of the set, but since it was made from spare parts in the junk box, the question of quality was not considered important. In the revised version of Fig. 2, a C battery is necessary for the successful operation of the output tube.

Another point of interest is the fact that the audio transformer used in Fig. 1 was replaced by a standard resistance-condenser combination. True, transformer coupling gives better results—from the standpoint of volume—than resistance coupling, but not in cases where the coupling takes place from a screen-grid tube. Many sets use the second or primary of audio transformers in place of the .1 meg. resistor shown in Fig. 2; however, the resistor is to be preferred. Try both and see which works better in your own case.

The changes shown are for operation from two dry cells in series; if operation from a six-volt source is desired, then the filament resistor should be changed to 15 ohms.

### Detector and Two Audio

Another combination of tubes used consists of a regenerative detector using an 01A and two audio stages, the first using an 01A and the second a 12A or 71A. A schematic circuit of such a receiver is shown in Fig. 3. Because of the obsolescence of the 01A tube, the same circuit may be considerably improved by rewiring the circuit to accommodate the new tubes.

**6-volt operation:** Figure 4 is the new circuit suitable for 6-volt operation. A 36 is used as the detector, a 37 in the first-audio stage, and an 38 in the last audio stage. The socket connections of these tubes appear in the insert in the figure. The first significant change is the use of a choke and resistor in place of the first a.f.t. in the plate circuit of the 36. This arrangement allows the d.c. plate current to pass through the choke with a minimum loss in voltage. The .25 meg. resistor across this choke is used as the coupling unit. The choke does not couple, because its impedance at 1,000 cycles is far greater than 250,000 ohms (.25 meg.), so that the resistor shorts it only as far as the signal is concerned. Thus, we gain one of the best advantages of the

impedance-coupled amplifier, and at the same time retain all the advantages of the resistance-coupled circuit.

The tubes used in this arrangement operate directly from the six-volt battery, so that a resistor in series with the heaters is not required. The action of this circuit is exactly the same as that before the change; the user, therefore, will not be required to get the "feel" of the receiver all over again. The increased response will more than compensate for the trouble and slight expense involved in making the changes.

In rewiring the sockets, be sure that you are acquainted with the socket terminals. Many men with plenty of inspiration and self-confidence have been brought down a peg or two after making a wrong connection on a socket. Don't guess, be sure. Analyze the original and final circuits carefully before going to work; for, as the old saying goes,

"It's better to erase a line than to change a wire."

**2-volt operation:** The circuit for 2-volt operation requires, of course, a different tube arrangement. In this case, we suggest a 32 as the detector, a 30 in the first a. f. stage, and 33 in the output stage. Here again we revert to the resistance-coupled idea discussed with reference to Fig. 2. For the benefit of those curious experimenters who want to know the "why" of everything, it might be well to state why a combination choke-resistance combination is used in one case, but not in another. The reason lies in the difference in plate resistance between the 32 and the 36. The type 32 tube has an internal plate resistance of 1.15 megohms, while the 36 has an internal plate resistance of but 200,000 ohms (.2 megohm). Since the higher impedance tube cannot have a choke of reasonable size in its plate circuit, because of the shunting effect of the distributed

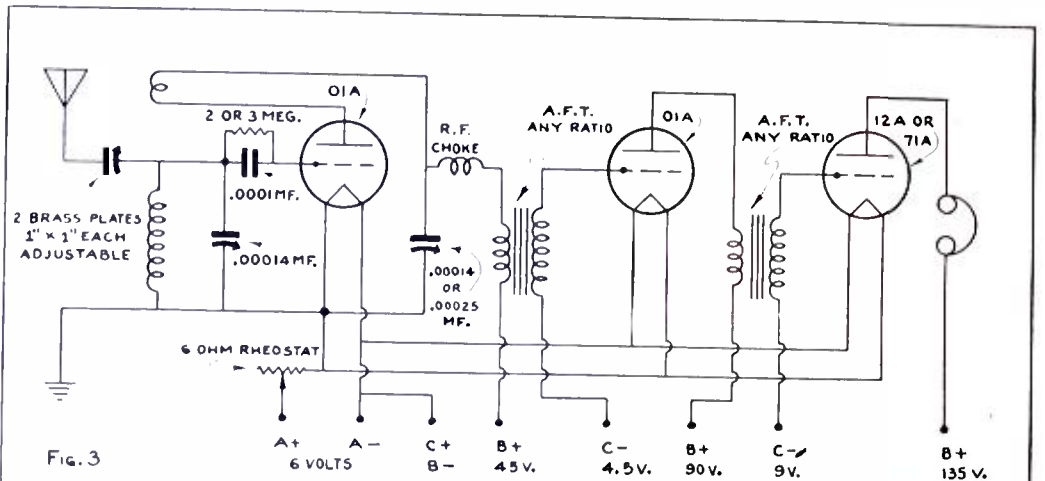

Fig. 3

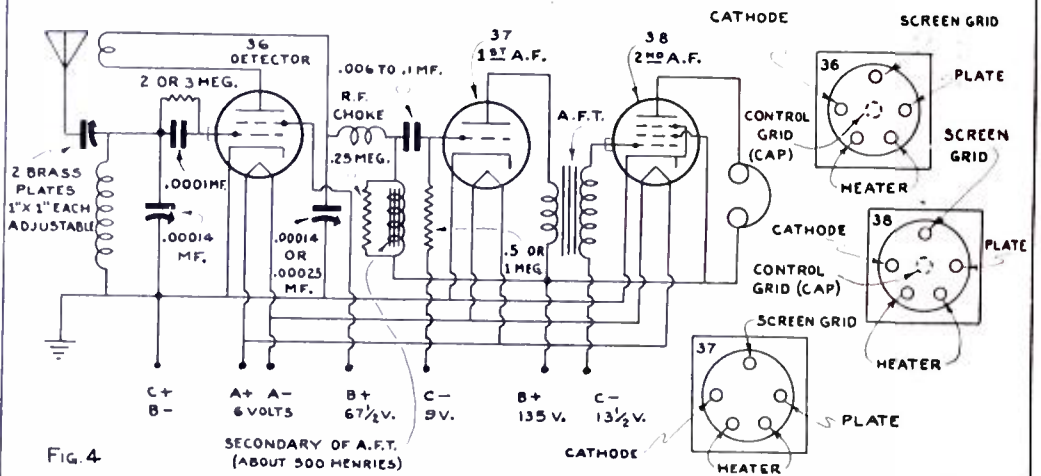

Fig. 4

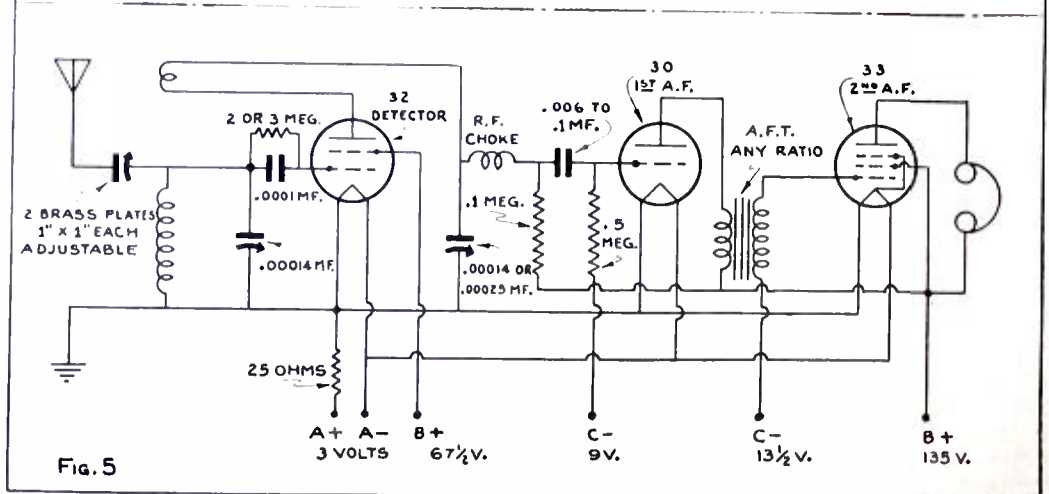

Fig. 5

REVISING THE "STANDARD" THREE-TUBE SET  
This set is easily "rehashed" for 6- and 2-volt operation.

capacity of the choke, resistances must be used; hence, the type 32 tubes have resistors in their plate circuits. Catch on?

The socket connection for the tubes used in the circuit of Fig. 5 are shown in either Fig. 2 or Fig. 4; the socket connections for the 30 used in Fig. 5 are exactly the same as for the 01A used previously.

### R. F., Detector, and Two Audio

In the four-tube field, the combination using a 22 as a tuned r.f. amplifier, an 01A as a detector, an 01A in the first-audio stage, and 12A or 71A in the last audio stage was extremely popular. A representative circuit using this combination is shown in Fig. 6. (This is the famous Pilot "Super-Wasp," probably the most popular s.w. re-

ceiver of the past ten years). Note that the antenna coil of this circuit is connected a little differently than the antenna coil of the preceding circuits. The reason for the change is simple: most of the coils used for s.w. work a few years ago had but two windings in order to accommodate a four-prong socket (there were no sevens in those days!). When the first tube is regenerative, one of the coils must be used as the secondary—the tuned circuit—and the other must be used as the tickler. In the case of the circuit of Fig. 6, the second tube is regenerative; therefore, the coil ordinarily used as the tickler is now used as the antenna coil. O.K.?

**6-volt operation:** For this class of service, all the sockets used in the old arrangement must be replaced by five-prong sockets. Although the

22 and the 36 are both screen-grid tubes, the 36 is equipped with a heater which requires an additional contact. Here again, (see Fig. 7) the first a.f. transformer is disconnected and its secondary used as a choke in the plate circuit of the detector; it is shunted by the .25 meg. (250,000 ohm) resistor for the reason described previously. Note, also, that the fixed resistor of 15 ohms, used in the original circuit to cut the filament voltage on the 22 tube to 3.3 volts, is not required in the revised circuit, as all tubes operate directly from a six-volt storage battery; the filament rheostat is also removed.

Other than the few major changes mentioned, the fundamental connections of the circuit remain the same. Although the difference in results will be marked, the changes are few and are certainly warranted. In rewiring the filament circuit, be sure that the heaters of the tubes connect only to the storage battery; to place heater and cathode at the same potential, which may give quieter operation in some cases, connect a center-tapped 20-ohm resistor across the heater terminals, and ground the center tap.

**2-volt operation:** This same original circuit lends itself very nicely to two-volt operation. The r.f. stage may be either a 32 or 34; the detector, a 32; the first audio, a 30; and the output stage, a 33. The schematic circuit of the revised diagram is shown in Fig. 8. Since the detector is a 32, the plate load must be a resistor, and is shown as such on the diagram. Because the tubes are rated at 2 volts, and since in all probability two dry cells will be used in series to supply the filament, a rheostat must be connected in series with the filament terminals to drop the voltage. Other than the few changes outlined, the circuit remains about the same. Only one socket will have to be changed—the last audio, from a four-prong to a five prong.

### Concluding Notes

Even though you may be interested in only one of the circuits shown here, do not fail to study the entire article because there may be some point that was not mentioned in connection with the one you are interested in, but which was covered when describing another set. Lack of space does not permit us to repeat every detail several times.

There is no doubt about the fact that many, many readers want information on rewiring their receivers for a.c. operation. They will not be disappointed; for in the following issues of SHORT-WAVE RADIO, details of modernizing obsolete receivers will be continued. In the meantime, if there are any questions pertaining to these articles that you would like answered, write in, but be sure to enclose a stamped, self-addressed envelope for reply. There is no charge for this service.

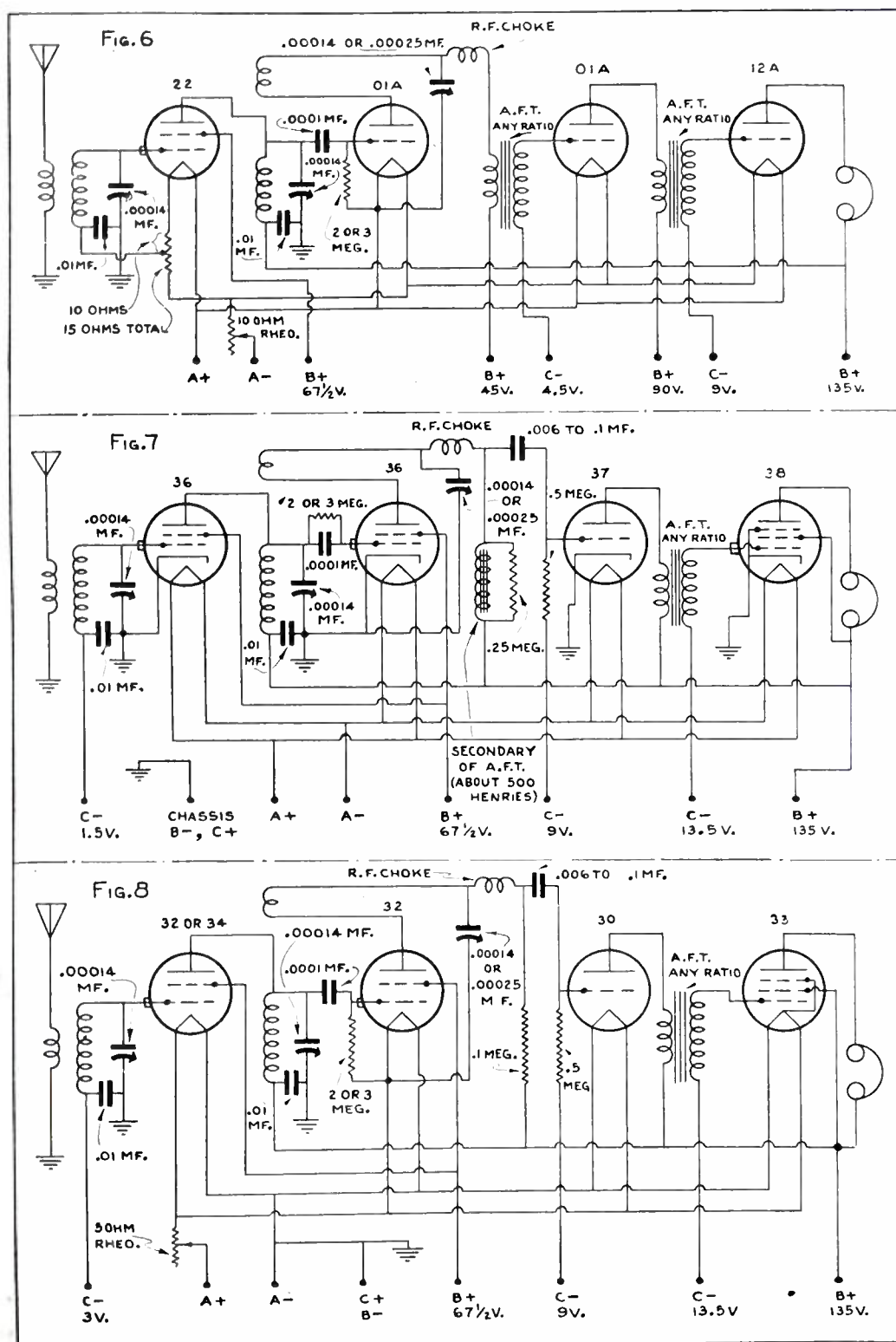

THE OLD FOUR-TUBE SET BEFORE AND AFTER  
Four of the modern tubes can do wonders for this old-timer.

# Naval Time-Signal Schedule

**T**HE first authentic time-signal schedule of the Navy Department received in a long time is tabulated at the right.

The time signals are of three orders of precision, each suitable for different classes of service. These different classes are indicated by one, two, and three asterisks, as explained in the chart. The time signals themselves are easily recognized, in the case of code, by short dots, a second in length.

We wish to thank Commander B. V. McCandlish, Acting Director of Naval Communications, for his excellent cooperation in preparing this tabulation for SHORT WAVE RADIO. The schedule is correct to October 1, 1933, insofar as it is possible to foretell at this time.

## Schedules for W3XAL and W3XL; Bound Brook, N. J.

W3XAL operates from 12:30 to 6:30 p. m. every day except Friday and Saturday on 17,780 kc.; and on Saturday, from 3:00 p. m. to 12:00 m. on 6,100 kc. Programs are generally the same as those of WJZ.

W3XL operates on 6,425 kc. with an irregular experimental schedule consisting mostly of experimental relay work; no regular transmission time can be given. Time is E. S. T.

## What About Television?

**T**HE present status of television was summed up in a short article which appeared in the *New York Times*. Mr. B. McCargar, president of Television Laboratories, Ltd., declared that television is ready for launching, but will require a large outlay of capital.

"As to the immediate future of television," he said, "air picture transmission will tend definitely toward the ultra short-wave channels with its own separate set-up."

The general inauguration of television will probably be sectional, and chain coverage will be practical only after the establishment of relay stations at intervals of about twenty-five to fifty miles.

Mr. McCargar also said that recent experiments showed that the useful range of television in the ultra short waves is about seventy-five miles, although the power of the transmitter was not stated.

The process used by the Television Laboratories is largely that developed by Phil T. Farnsworth who, at the age of 22, designed the first cathode-ray tubes for both reception and transmission with electrical scanning.

Time (Greenwich civil)	Station	Call Sign	Frequency in kilocycles and type of emission, A1 unless otherwise noted	Material Broadcast
0255 to 0300 (9:55 to 10:00 P.M. E.S.T.)	Washington, D. C.....	NAL	690 A3.....	Time signals.*
	Arlington, Va. (Washington, D. C.)....	NAA	{113..... 9,050.....	
	Annapolis, Md. (Washington, D. C.)....	NSS	17.8 A.....	
	Mare Island (San Francisco, Calif.).....	NPG	42.8 A; 108; 12,885	
0355 to 0400 (10:55 to 11 P.M. E.S.T.)	Honolulu (Pearl Harbor), T. H.....	NPM	16,180.....	Rebroadcast of Washington, D. C. Time signals.*
	Darien (Balboa), C. Z.....	NBA	46.....	
0425 to 0430 (11:25 to 11:30 A.M. E.S.T.)	Cavite (Los Banos), P. I.....	NPO	{56 A2..... 8,872..... 17,744.....	Time signals.*†
	Annapolis, Md. (Washington, D. C.)....	NSS	{17.8 A..... 4,525..... 113.....	
0455 to 0500 (11:55 to 12:00 Noon E.S.T.)	Arlington, Va. (Washington, D. C.)....	NAA	17.8 A.....	Time signals.*
	Annapolis, Md. (Washington, D. C.)....	NSS		
0755 to 0800 (2:55 to 3:00 A.M. E.S.T.)	(Arlington, Va. (Washington, D. C.)....	NAA	{113 A2..... 9,050.....	Time signals.*
	Mare Island (San Francisco, Calif.).....	NPG	{42.8 A; 108; 8,590	
	Honolulu (Pearl Harbor), T. H.....	NPM	8,090.....	
	Cavite (Los Banos), P. I.....	NPO	{22.9..... 9,050.....	
1255 to 1300 (7:55 to 8:00 A.M. E.S.T.)	Washington, D. C.....	NAL	690 A3.....	Time signals.*
	Arlington, Va. (Washington, D. C.)....	NAA	{113 A2..... 8,410..... 12,615..... 16,820.....	
	Annapolis, Md. (Washington, D. C.)....	NSS	17.8 A.....	
	Mare Island (San Francisco, Calif.).....	NPG	{42.8 A; 108; 12,885.....	
1655 to 1700 (11:55 to 12:00 Noon E.S.T.)	Honolulu (Pearl Harbor), T. H.....	NPM	8,090.....	Rebroadcast of Washington, D. C. Time Signals.*
	Darien (Balboa), C. Z....	NBA	46.....	
1755 to 1800 (12:55 to 1:00 P.M. E.S.T.)	Annapolis, Md. (Washington, D. C.)....	NSS	17.8 A.....	Time signals.*
	Arlington, Va. (Washington, D. C.)....	NAA	9,050 and 113....	
2055 to 2100 (3:55 to 4:0 P.M. E.S.T.)	Arlington, Va. (Washington, D. C.)....	NAA	9,050 and 113....	Time signals.*
	Honolulu (Pearl Harbor), T. H.....	NPM	{26.1..... 106.....	

\*First-order time signals. These are precision time signals for chronometer rating and scientific use, normally correct as broadcast to less than one-tenth of a second.

\*\*Second-order time signals. These are time signals for chronometer rating and ordinary use, normally correct as broadcast to less than five-tenths of a second, having a generally constant lag.

\*\*\*Third-order time signals. These time signals are satisfactory for ordinary commercial and domestic timing, but not satisfactory for chronometer rating or precision timing, on account of a varying lag within comparatively wide limits.

†Controlled by Manila Central Observatory.

IType A, continuous wave.

IType A1, unmodulated continuous wave.

IType A2, continuous wave modulated at audible frequency.

IType A3, continuous wave modulated by speech.

NOTE.—In the event of a failure or an error occurring in any of the time signals, except the rebroadcast of Washington time signals at San Francisco and Honolulu, another time signal will be transmitted one hour later on the same frequency. San Francisco, in the event of a failure or error occurring in the Washington time signal, will transmit a time signal from the clock at that point. For Eastern Standard Time, subtract five hours from Greenwich times listed.



# RADIO SYMBOLS

FILAMENT-TYPE DIODE, HALF-WAVE RECTIFIER	FILAMENT-TYPE FULL-WAVE RECTIFIER	DIODE RECTIFIER WITH CATHODE	THREE ELEMENT FILAMENT-TYPE TRIODE	FULL-WAVE RECTIFIER WITH CATHODE-HEATER	THREE ELEMENT HEATER-CATHODE TRIODE	FOUR ELEMENT FILAMENT-TYPE TETRODE
FOUR ELEMENT CATHODE-HEATER TETRODE	FIVE ELEMENT FILAMENT-TYPE PENTODE	FIVE ELEMENT HEATER-CATHODE PENTODE	FILAMENT-TYPE DOUBLE TRIODE	DOUBLE TRIODE, CATHODE-HEATER TYPE	DOUBLE DIODE-TRIODE, FILAMENT TYPE	DOUBLE DIODE-TRIODE, CATHODE-HEATER TYPE
DOUBLE DIODE-PENTODE, FILAMENT TYPE	DOUBLE DIODE-PENTODE, CATHODE-HEATER TYPE	TRIODE-PENTODE FILAMENT TYPE	TRIODE-PENTODE CATHODE HEATER TYPE	HEATER-CATHODE TYPE TRIODE-PENTODE	PHOTO-ELECTRIC CELL	LAMP (ANY TYPE)
FIXED RESISTOR	VARIABLE RESISTOR (EITHER ONE)	POTENTIOMETER	FIXED INDUCTANCE OR R.F. CHOKE	VARIABLE INDUCTANCE (EITHER ONE)	R.F. TRANSFORMER	LOW FREQUENCY CHOKE
AUTO-TRANSFORMER	LOW FREQUENCY TRANSFORMER	FIXED CONDENSER	VARIABLE CONDENSER	BATTERY	AERIAL (ANTENNA)	GROUND
AMMETER	VOLTMETER	MILLI-AMMETER	CRYSTAL DETECTOR	PIEZO-CRYSTAL	SINGLE CIRCUIT JACK	DOUBLE CIRCUIT JACK
PHONES	MAGNETIC SPEAKER	DYNAMIC SPEAKER	SINGLE BUTTON CARBON MICROPHONE	DOUBLE BUTTON CARBON MICROPHONE	KEY	S.P.D.T. SWITCH
S.P.S.T. SWITCH	D.P.S.T. SWITCH	D.P.D.T. SWITCH	TAP OR ROTARY SWITCH	CONDENSER MICROPHONE	FUSE	

© STANDARD PUBLICATIONS, INC.  
SHORT WAVE RADIO · NOV. 1933

The radio symbols shown above are those used officially in this magazine, although at times there may be slight deviations, especially in cases where a change would clarify matters.

The tubes are especially important. The grids are labeled from 1 up, starting with the cathode, in all cases, regardless of which grid is the control grid. This scheme is shown by the labels on one of the

symbols. The control grid will be indicated in the actual schematic by a cap projecting from the tube.

The remaining symbols are standard, and the reader should have little difficulty with them.



# The Denton Trophy Contest

**SUMMARY:** *Trophies have been donated time and time again to those qualified to be recognized as champions. This is especially true in amateur sports, and has been extended in many cases to include the less physically violent sport of short-wave reception.*

*Mr. Clifford E. Denton, well-known radio experimenter and design engineer, is offering a trophy to the one receiving the greatest number of long-distance stations; aside from the trophy, which is first prize, ninety-nine other prizes are to be awarded to those following. Mr. Denton is to be congratulated for his excellent foresight in sponsoring a non-commercial contest of this type. The rules are printed below in full; save them for future reference.*

**T**HE Denton Trophy Contest offers every short-wave listener an opportunity to earn fame and also a more substantial reward in the form of a handsome trophy or one of ninety-nine other prizes.

The idea of this contest was conceived by Clifford E. Denton, well-known short-wave designer, as a non-commercial means of promoting interest in short-wave reception. It is Mr. Denton's plan to make his trophy contest similar in the short-wave field to the Davis Cup competition in the sport of tennis.

Mr. Denton explained his idea to various leaders in short-wave work, and everywhere the plan was endorsed most enthusiastically. The International Short Wave Club of Klondyke, Ohio, placed its entire resources at the disposal of the Trophy Committee. Capt. H. L. Hall, internationally famous as a short-wave experimenter, also started to boost the plan and before long, the contest became a reality.

The name of the contest was selected in honor of its originator, Mr. Denton, and also because of the fact that he is donating the first prize, a silver globe representing the earth. The winner's name and a record of his achievement will be suitably engraved on the trophy.

The rules governing the Denton trophy contest are set forth as follows:

The contest is known as the Denton Trophy Contest. The silver trophy, constituting the first prize, will be presented by Clifford E. Denton.

The second prize will be a medal, suitably engraved and designed, bearing the name of the winner and will mention the circumstances under which it was awarded.

The third prize will be a medal similar to the second prize.

The fourth to one hundredth awards will consist of engraved scrolls in the form of honorable men-

## Radio Club News

*News of radio club activities is welcomed by SHORT WAVE RADIO and will be published monthly in a regular department. Club secretaries are requested to send in brief reports, which should always include the place, date, and time of meetings. This publicity will be very helpful in increasing membership and furthering the short-wave "game" in general.*

*Good photographs of the club members, the club station or meeting room, etc., are especially desirable. Prints should be not smaller than 5 x 7 inches, on glossy paper.*

tion certificates, suitably inscribed with the names of the winners and calling attention to the excellence of their receiving ability.

All of the prizes will be awarded to the respective winners by the International Short Wave Club of Klondyke, Ohio.

Any short-wave listener-in in any part of the world is eligible to take part in this contest without entry fee or any other obligation or expense whatsoever.

The prizes will be awarded to the contestants presenting the greatest number of verifications from short-wave stations transmitting broadcast programs such as music and speech, intended for the purpose of entertainment. In case of a tie, mileage will be computed, and the question of superiority will be decided upon the basis of the total number of miles received. This will be the air line distance between the receiver and each of the transmitters. The findings on this question of mileage will be made by the judges and will be considered final.

All rulings of the judges are to be

final. Only one prize will be awarded to any one winner. Judges, nor members of their families, will not be permitted to compete in this contest.

The judges of the contest will include: O. H. Caldwell, Former member of Federal Radio Commission and Editor of ELECTRONICS; H. G. Cisin, Radio Writer and Inventor; Lawrence M. Cockaday, Editor of RADIO NEWS; Clifford E. Denton, Consultant, Lecturer, and Author; Arthur J. Green, President, International Short Wave Club; Capt. H. L. Hall, Lt. Commander, U. S. Navy, retired; Jacob Kleimans, Member Advisory Board of the International Short Wave Club; Arthur H. Lynch, Originator of first International Broadcasting Contest, started in 1923; Joseph G. Reaney, Chairman, New York Chapter, International Short Wave Club; Joseph B. Sessions, Member Advisory Board of International Short Wave Club.

The contest began August 1, 1933 and will terminate February 1, 1934. Ample time is thus provided so that fans in any part of the world will have an equal chance to participate in the contest.

All verifications must be submitted by April 15th, 1934. Prizes will be awarded at the earliest possible moment after April 15th, 1934, depending upon the amount of work involved in the compilation of the records. The date of the awards will be announced in the press.

Judges will assume no responsibility for any verifications unless they are listed and receipted for, or sent by registered mail.

Verifications must bear post-marks or dates, indicating that the program was received by the contestant between August 1st, 1933 and February 1st, 1934.

Verifications will be accepted for entry into the contest from any part of the world. The verifications and lists must be forwarded to Clifford E. Denton, 23 Park Place, New York,

(Continued on page 46)

# SHORT WAVE RADIO'S

# Short-Wave Station List

**T**HE following list, conveniently arranged alphabetically according to call letters, represents practically all the short-wave stations of the world, except amateur, that use voice transmission and are therefore recognizable by listeners who do not know the code. In each case the frequency in kilocycles, the corresponding wavelength in meters, and the location by city are given; the country of origin, where it is not obvious, may quickly be determined from the preliminary list of international call letter assignments. Amateur and some special experimental calls consist of the assigned prefix, followed by a number and usually two or three more letters.

No attempt has been made to in-

clude operating schedules in this list, as a great majority of the stations are experimental in nature, and have the habit of changing announced programs without warning. Up-to-the-minute information on the best stations of the month is contained in another department in this issue.

For the sake of brevity, a number of abbreviations of operating company names are used. These are RCA, Radio Corporation of America; GPO, General Post Office; BBC, British Broadcasting Corporation; CBS, Columbia Broadcasting System; NBC, National Broadcasting Company; GE, General Electric Company; ATT, American Telegraph & Telephone Co.; MRT, Mackay Radio Telegraph Co.

## List of International Call Assignments

Block of Calls	Country	Amateur Prefix	Block of Calls	Country	Amateur Prefix	Block of Calls	Country	Amateur Prefix
CAA-CEZ	Chile	CE	J	Japan	J	VOA-VOZ	Newfoundland	VO
CFA-CKZ	Canada	VE	K	United States of America:		VPA-VSZ	British colonies and protectorates	
CLA-CMZ	Cuba	CM		Continental United States	W		British Guiana	VP
CNA-CNZ	Morocco	CN		Philippine Ids.	KA		Fiji, Ellice Ids., Zanzibar	VPI
CPA-CPZ	Bolivia	CP		Porto Rico and Virgin Ids.	K4		Bahamas, Barbados,	
CQA-CRZ	Portuguese colonies:			Territory of Hawaii	K6		Jamaica	VP2
	Cape Verde Ids	CR4	LAA-LNZ	Norway	K7		Bermuda	VP9
	Portuguese Guinea	CR5	LOA-LVZ	Argentine Republic	LU		Fanning Id.	VQ1
	Angola	CR6	LZA-LZZ	Bulgaria	LZ		Northern Rhodesia	VQ2
	Mozambique	CR7	M	Great Britain	G		Tanganyika	VQ3
	Portuguese India	CR8	N	United States of America	W		Kenya Colony	VQ4
	Macao	CR9	OAA-OCZ	Peru	OA		Uganda	VQ5
	Timor	CR10	OFA-OHZ	Finland	OH		Malaya (including Straits Settlements)	VS1-2-3
CSA-CUZ	Portugal:		OKA-OKZ	Czechoslovakia	OK		Hongkong	VS6
	Portugal proper	CT1	ONA-OTZ	Belgium and colonies	ON		Ceylon	VS7
	Azores	CT2	OUA-OZZ	Denmark	OZ	VTA-VWZ	British India	VU
	Madeira	CT3	PAA-PIZ	The Netherlands	PA	W	United States of America:	
CA-CVZ	Rumania	CV	PJA-PJZ	Curacco	PJ		Continental United States	W
CWA-CXZ	Uruguay	CX	PKA-POZ	Dutch East Indies	PK		(for others, see under K.)	
CZA-CZZ	Monaco	CZ	PPA-PYZ	Brazil	PY	XAA-XFZ	Mexico	X
D	Germany	D	PZA-PZZ	Surinam	PZ	XGA-XUZ	China	AC
EAA-EHZ	Spain	EAR	RAA-RQZ	U. S. S. R. ("Russia")	RA	YAA-YAZ	Afghanistan	YA
EIA-EIZ	Irish Free State	EI	RVA-RVZ	Persia	RV	YHA-YHZ	New Hebrides	YH
ELA-ELZ	Liberia	EL	RXA-RXZ	Republic of Panama	RX	YIA-YIZ	Iraq	YI
EZA-ESZ	Esthonia	ES	RYA-RYZ	Lithuania	RY	YLA-YLZ	Latvia	YL
ETA-ETZ	Ethiopia (Abyssinia)	ET	SAA-SMZ	Sweden	SM	YMA-YMZ	Danzig	YM
F	France (including colonies):		SPA-SRZ	Poland	SP	YNA-VNZ	Nicaragua	YN
	France proper	F	STA-SUZ	Egypt:		YSA-YSZ	Republic of El Salvador	YS
	French Indo-China	F1		Sudan	ST	YVA-YVZ	Venezuela	YV
	Tunis	FM4		Egypt proper	SU	ZAA-ZAZ	Albania	ZA
	Algeria	FM8	SVA-SZZ	Greece	SV	ZBA-ZHZ	British colonies and protectorates	
G	United Kingdom:		TAA-TCZ	Turkey	TA		Transjordan	ZC1
	Great Britain except Ireland	G	TFA-TFZ	Iceland	TF		Palestine	ZC6
	Northern Ireland	GI	TGA-TGZ	Guatemala	TG		Nigeria	ZD
HAA-HAZ	Hungary	HA	TIA-TIZ	Costa Rica	TI		Southern Rhodesia	ZE1
HBA-HBZ	Switzerland	HB	TSA-TSZ	Territory of the Saar Basin	TS	ZKA-ZMZ	New Zealand:	
HCA-HCZ	Ecuador	HC	UHA-UHZ	Hedjaz	UH		Cook Ids	ZK
HAHA-HHZ	Haiti	HH	UIA-UKZ	Dutch East Indies	PK		New Zealand proper	ZL
HIA-HIZ	Dominican Republic	HI	ULA-ULZ	Luxemburg	UL		British Samoa	ZM
HJA-HKZ	Colombia	IJ	UNA-UNZ	Yugoslavia	UN	ZPA-ZPZ	Paraguay	ZP
HRA-HRZ	Honduras	HR	UOA-UOZ	Austria	UO			ZS
HSA-HSZ	Siam	HS	UWA-VGZ	Canada	VE	ZSA-ZUZ	Union of South Africa	ZT
I	Italy and colonies	I	VHA-VMZ	Australia	VK			ZU





WPKD	2,450 kc., 122.4 m.	Memphis, Tenn.	WPFJ	1,712 kc., 175.15 m.	XETE	9,600 kc., 31.25 m.	
WPKL	2,442 kc., 122.8 m.	WPEE	2,450 kc., 122.4 m.	Hammond, Ind.	XEW	6,023 kc., 49.8 m.	
WPKM	2,430 kc., 123.4 m.	WPEF	2,450 kc., 122.4 m.	Hackensack, N. J.	XIF	6,167 kc., 48.65 m.	
WPKN	2,458 kc., 122. m.	WPEG	2,450 kc., 122.4 m.	Gary, Ind.		Mexico City, Mex.	
WPKO	2,458 kc., 122. m.	WPEH	1,712 kc., 175.15 m.			—Y—	
WPKP	2,470 kc., 121.5 m.	WPEI	1,712 kc., 175.15 m.	Birmingham, Ala.	YNA	14,500 kc., 20.69 m.	
WPKR	2,458 kc., 122. m.	WPEJ	1,712 kc., 175.15 m.	Fairhaven, Mass.	YV1BC	6,110 kc., 49.1 m.	
WPKS	2,416 kc., 124.1 m.	WPEK	2,422 kc., 123.8 m.	Knoxville, Tenn.	YV11BMO	6,130 kc., 48.95 m.	
WPKT	2,470 kc., 121.5 m.	WPEL	1,574 kc., 189.5 m.	Clarksburg, W. Va.	YV1BC	6,120 kc., 49.02 m.	
WPKU	1,712 kc., 175.15 m.	WPEM	1,712 kc., 175.15 m.	Swarthmore, Pa.	YV2AM	14,110 kc., 21.26 m.	
WPKV	2,458 kc., 122. m.	WPEP	1,712 kc., 175.15 m.	Johnson City, Tenn.	YV3BC	6,130 kc., 48.9 m.	
WPKW	2,422 kc., 123.8 m.	WPEQ	1,574 kc., 189.5 m.	Grosse Pt. Village, Mich.		9,510 kc., 31.56 m.	
WPKX	2,414 kc., 124.2 m.	WPER	1,712 kc., 175.15 m.	WRDII		Caracas, Venezuela	
WPKY	2,414 kc., 124.2 m.	WPEF	2,442 kc., 122.8 m.	Cleveland, Ohio	YVQ	11,690 kc., 25.65 m.	
WPDZ	2,470 kc., 121.5 m.	WPEG	2,430 kc., 123.4 m.	WRDR		13,500 kc., 22.48 m.	
WPEA	2,458 kc., 122.8 m.	WPEH	2,442 kc., 122.8 m.	WRDQ		18,300 kc., 16.39 m.	
WPEB	2,442 kc., 122.8 m.	WPEI	2,430 kc., 123.4 m.			Maracay, Venezuela	
WPEC	2,470 kc., 121.5 m.	WPEJ	2,442 kc., 122.8 m.			—Z—	
		WPEK	2,442 kc., 122.8 m.			ZGE	6,000 kc., 50 m.
		WPEL	2,430 kc., 123.4 m.				Kuala, Lumpur, Malay States
		WPEM	2,442 kc., 122.8 m.			ZLZZX	6,060 kc., 49.5 m.
		WPEP	2,442 kc., 122.8 m.			ZLZT	7,390 kc., 40.6 m.
		WPEQ	2,442 kc., 122.8 m.				10,990 kc., 27.3 m.
		WPER	2,414 kc., 124.2 m.			ZLW	12,300 kc., 24.4 m.
		WPEF	2,414 kc., 124.2 m.				18,340 kc., 16.35 m.
		WPEG	2,414 kc., 124.2 m.				10,980 kc., 27.3 m.
		WPEH	2,414 kc., 124.2 m.			ZL2XX	4,770 kc., 62.8 m.
		WPEI	2,414 kc., 124.2 m.				Wellington, New Zealand

# The Before Breakfast Short Wave Club

Originated and sponsored by the editors of Short Wave Radio

**M**ANY owners of short-wave receivers do not realize that the early morning hours are usually much better for long-distance reception, particularly from European stations, than the evening hours.

There are several reasons for this. First and most important, the time difference works out more advantageously from the standpoint of American listeners. When it is 7:00 a. m. in New York or Philadelphia, for instance, it is between noon and 2:00 in the afternoon in Europe, and many stations are going full blast with the day's programs. Second, there is daylight over the entire path of transmission between the Continent and almost half of the United States, and reception at the low end of the dial, between 13 and approximately 23 meters, is very good. A third and important reason is the comparative quietness of the air early in the morning. Automobile traffic is still light and ignition racket, therefore, inconsequential. Office buildings, factories and industrial plants of various kinds are still closed and, therefore, the background of "soup," so annoying during the day, has not yet been created by motors, oil burners, signs and hundreds of other electrical machines. Fourth, the listener himself, having just arisen from what we hope is a good night's sleep, feels better than he does at the end of a

day's work, and is likely to exercise more patience in turning his dials. Short-wave fans who make a habit of listening in regularly before breakfast enjoy highly interesting reception from stations they could not possibly hear in the evening.

To encourage more of this sort of thing, SHORT WAVE RADIO is hereby organizing the Before Breakfast Short Wave Club, membership in which will be open to all short-wave fans regardless of the nature of their receivers. There will be no dues, meetings, minutes or other parliamentary nuisances. It will merely be a friendly, fraternal organization of early birds who believe in the old adage about catching the worm. The only requirement for membership will be at least two verifications from short-wave phone stations 1,000 miles or more from the applicant's location, received any time after 5:00 a. m. and before 9:00 a. m. any day of the week.

Verifications sent in to the Before Breakfast S. W. Club will be returned promptly to their senders, along with a small certificate of membership suitable for framing. The exact form of this certificate has been determined and is reproduced in full size on the next page. As may be seen and appreciated, the fancy script illustrates the dignity of the Club, and the early-morning utensils constitute a symbol

We do not make any distinctions between short-wave relay broadcasting stations, commercial radiophones, amateur phones, experimental stations, and ship stations. Any station that operates below 200 meters and uses voice transmission is a legitimate catch for the short-wave listener, who is interested only in the feat of reception itself and not in the musical programs, political propaganda and private conversations that fill the air. It is really much more of an accomplishment to bring in an amateur station using perhaps only ten or fifteen watts of power than a powerful broadcasting station using ten or fifteen thousand watts.

Come on, boys, let's see what you can do. Honorable mention will be made each month of the listener who bags the greatest number of stations during any one week of the calendar month. Your letters and cards will undoubtedly contain valuable "dope" on wavelengths and operating hours of elusive stations, which we will publish for the benefit of less fortunate listeners.

Address your verifications and applications for membership to the Before Breakfast S. W. Club, care of SHORT WAVE RADIO, 1123 Broadway, New York, N. Y., and be sure to enclose a large stamped and addressed envelope for their safe return.

Don't wait, send your "veries" now!

# Before Breakfast Short Wave Club



**T**his is to certify that \_\_\_\_\_

has qualified for Membership in the  
"Before Breakfast Short Wave Club"  
by satisfying the requirements as  
published in "Short Wave Radio."

NEW YORK \_\_\_\_\_

EDITOR "SHORT WAVE RADIO"

**Full size reproduction of the diploma sent free of all charges to listeners who qualify. There is absolutely no cost or obligation involved; merely send in two verifications from telephone stations 1,000 miles away, and the diploma is yours. Read the full rules on the opposite page.**

# How to get Started on 5-Meter Work

**SUMMARY:** Many short-wave experimenters would like to get started on 5-meter work, but don't know how to do it. We have attempted to start off on the right foot by describing a simple, but very effective, 5-meter receiver of the super-regenerative type. This set has been in use for some time and has given excellent results in every respect.

The 5-meter band contains very interesting amateur phone communications, television signals, and experimental and regular-scheduled police communications. Last but not least, this band is free from much of the static that prevails on the lower frequencies and is unmarred by telegraphic interference.

If the present trend of radio is any criterion, then five-meter is certain to become one of the most popular bands in the short-wave field. True, there are not many stations operating on 5 meters at the present time, but the trend is definitely that way. Most of you who have constructed broadcast receivers and then turned to the short-wave bands for real long-distance reception, have realized the radical change in circuit requirements necessary in short waves compared to the broadcast band. By the same token, circuit requirements and operating procedure on the 56-megacycle band (5.3 meters) is radically different from that on the 15- or 40-meter bands.

The sensitivity of the usual circuit at 5 meters is so low that it would be well-nigh impossible to hear anything with the usual arrangements. If any attempt is made to increase the sensitivity of a receiver by adding more r.f. stages, then one is faced with the problems of capacitive and magnetic coupling, which are, at the present time, practically insurmountable.

In 5-meter work, therefore, we must look to some different circuit arrangement that is far more sensitive than the usual and that may be readily adaptable to ultra-high-frequency work. Examination of known circuits shows that only two may be generally used: the superheterodyne and the super-regenerative circuits. The advantage of the superhet lies in the fact that r.f. amplification takes place at a relatively low frequency where instability is not an important factor. In this case, then, all one needs is a single tuned r.f. stage, together with the usual oscillator and low-frequency amplifier; and since only one stage is in the ultra-high-frequency band, coupling effects are minimized—hence the stability of the super. In this connection, it might be well to point out that the super has not found much favor in 5-meter work, for the simple reason that the cost of the tubes and the parts required for satisfactory operation overbalances the results obtained. Therefore, we must resort to super-regeneration to obtain the necessary gain and stability demanded in 5-meter work.

By Arthur Hertzberg

Super-regeneration



OUT IN THE FIELD

This 5-meter set is completely self-contained. It is ideally suited for a tripod, too.

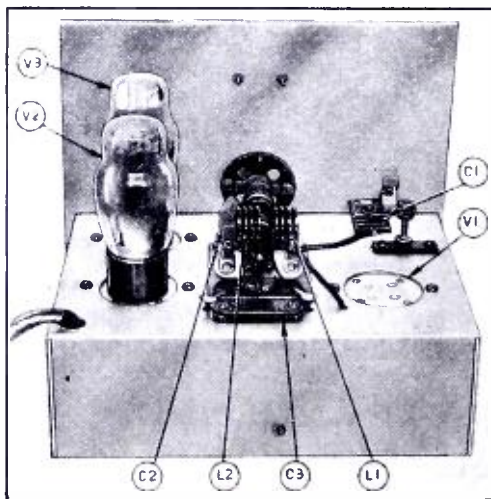

REAR VIEW OF THE 5 METER SET

The two coils are visible directly behind the tuning condenser.

An elementary explanation of super-regeneration is best made by an analysis of an ordinary 3-circuit tickler receiver. Suppose you were to sit down at such a set, turn it on, and tune in a station. Let us suppose that the tickler is set in such a position that the set is *not* oscillating. Now, of course, your natural desire is to get more signal strength, so that the first thing you do is to advance the tickler toward the point of oscillation; furthermore, you advance it slowly. As the tickler is advanced, the signal strength increases slowly at first, and then more rapidly as the oscillation point is reached. In fact, it seems that when you are very close to this point of oscillation, a vernier on the tickler dial would be a great aid toward getting as close as possible to this point. Suddenly, when the signal strength seems a maximum, the tube breaks into oscillation, and, of course, the volume drops, the signals get mushy, and the usual symptoms of self-sustained oscillations manifest themselves.

If it were only possible to maintain the tube in such a condition that we were always as close as possible to the point of oscillation, then the signal strength would be thousands of times that obtained if only a little regeneration were used. *This is exactly what super-regeneration does.*

The manner in which super-regeneration performs this seemingly remarkable feat is simple. Suppose, for illustration purposes, the tickler in our little imaginary set were placed in such a position that the receiver oscillates. Again, suppose that we can cut out the oscillation by gradually reducing the plate voltage. We all know from experience that a reduction in plate voltage stops the tube from oscillating. In super-regeneration, the varying of the plate voltage is performed by means of a separate oscillator tuned to a frequency far below that to which the tuned circuit is adjusted—about 15,000 or 20,000 cycles. This oscillator is so connected in the plate circuit of the tube to be controlled, that the actual plate voltage applied to the tuned stage is equal to the B battery voltage plus or minus this oscillator voltage. During one-half



of the oscillator cycle, the oscillator voltage adds to the plate voltage, making the tube oscillate, and on the other half of the cycle the oscillator voltage is bucking the steady plate voltage, making the tube stop oscillating.

The result is that when the oscillator voltage is aiding the B battery voltage, the tube starts to regenerate; but because the voltage is variable and starts to drop, the tube actually does not have sufficient time to build up to the point where oscillation actually begins. In other words, during one-half of the oscillator cycle, regeneration is building up very close to the point of oscillation, and on the other half of the cycle it is building down, so to speak. The tube, therefore, is always on the verge of oscillation, but is never actually oscillating, so that we have satisfied our conditions for maximum response with good stability. This separate oscillator, commonly called a *quencher*, may, if so desired, be placed in the grid circuit, but the circuit is much more stable when connected in the plate circuit.

It is easily appreciated, now, that the greater the difference between the quenching frequency and the signal frequency, the more stable the circuit; for if both were nearly the same, a.f. signals would be sure to develop, the circuits would tend to "pull" into synchronism, and the result would be worse than if no quencher were used at all. That is another reason why super-regeneration works so well on ultra-high frequencies.

#### Our 5-Meter Receiver

The receiver to be described here is not the finest that can be built, nor is it the worst. It is a receiver that has given excellent results and that is especially suitable for the man engaged in short-wave work who wants to know more about 5-meter stuff. Once the peculiarities of 5-meter reception have been mastered, he may step ahead to more complicated and more sensitive sets.

The photographs and the diagrams illustrate completely the receiver it-

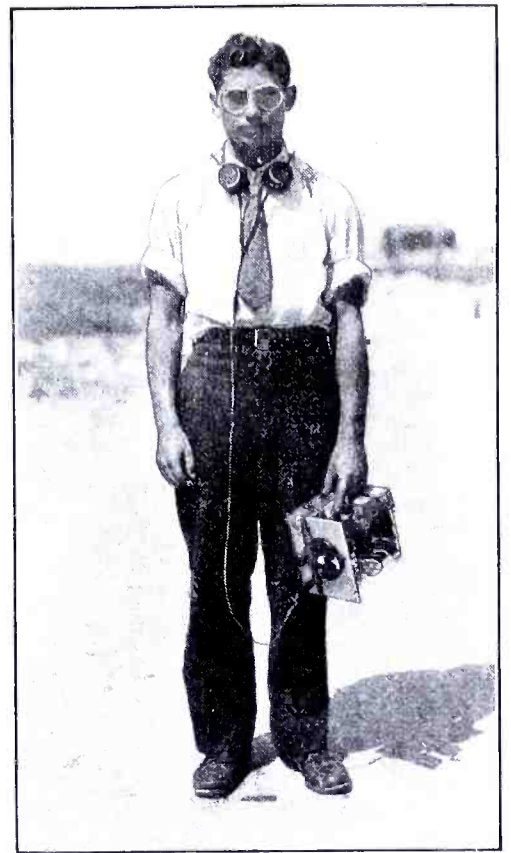

THE 5-METER RECEIVER IN A CAR AND IN THE FIELD

Its small size and the fact that the batteries are a part of the receiver itself make this set fit for a car or for portable work in the field. The A and B batteries are strapped to the receiver proper.

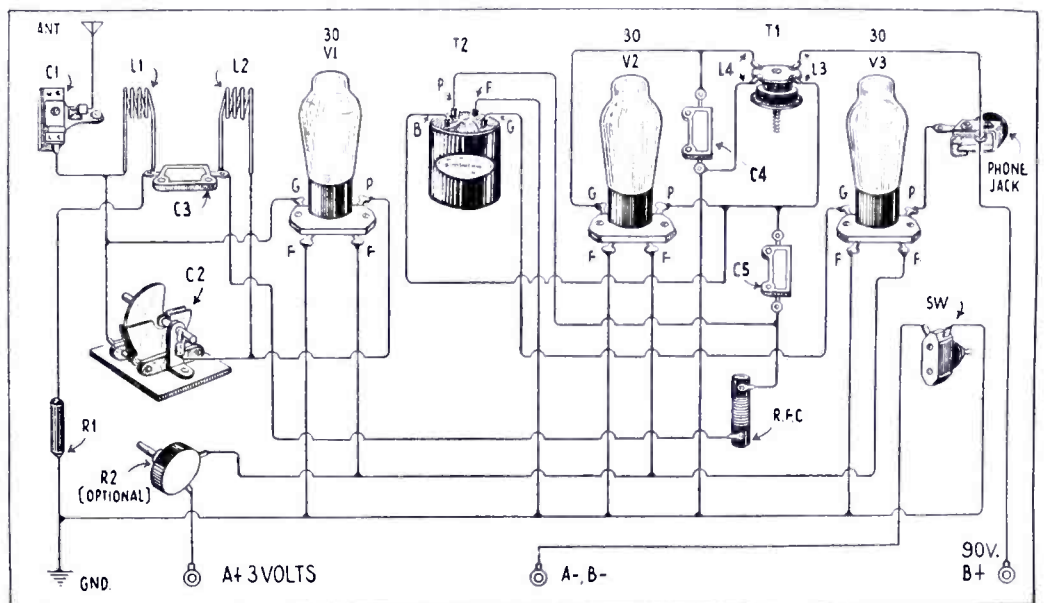

PICTORIAL WIRING DIAGRAM OF THE 5-METER RECEIVER

The connections here are the same as those given in the schematic below.

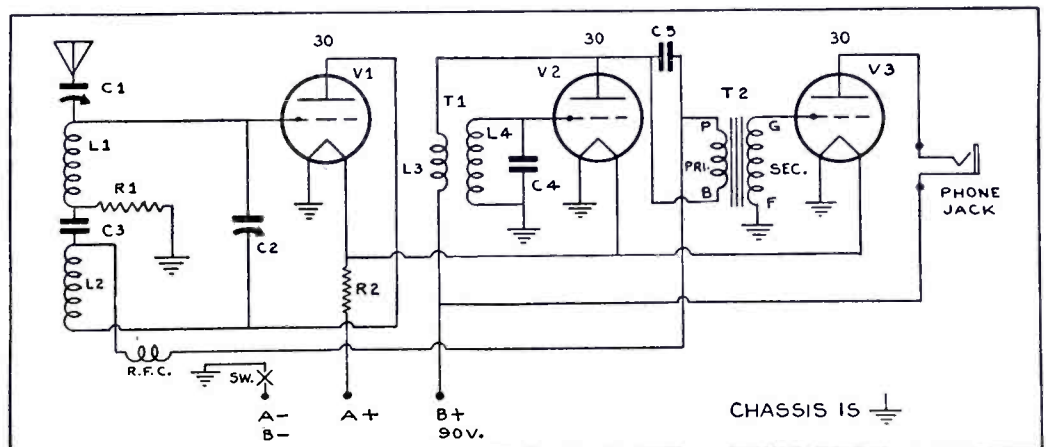

SCHEMATIC CIRCUIT OF THE 3-TUBE, 5-METER RECEIVER

Complete schematic diagram of the set. Either the wiring diagram here or the point-to-point diagram above may be used to connect up this set. The list of parts is shown to the left.

- C1—Hammarlund postage-stamp trimmer.
- C2—20 mmf. variable Hammarlund, MC-20-S.
- C3—.0001 mf. fixed condenser.
- C4—.002 mf. fixed condenser.
- C5—.002 mf. fixed condenser.
- R1—1 megohm fixed resistor.
- R2—15-ohm rheostat.
- T1—Quenching frequency oscillator coils (F. W. Sickles Co.).
- T2—Hegehog audio transformer.
- J—Single open-circuit phone jack.
- R.F.C.—5-meter R.F. choke.
- V1, V2, V3—Type 30 tubes (Sylvania).
- 3—4-prong Isolantite sockets (Hammarlund).
- SW.—Snap switch.
- 1—Vernier dial (National type B).
- Bakelite or hard rubber 2 x 2 1/4 x 1/8" for condenser mount.
- 1—Insulated flexible coupling (Hammarlund).
- 1—Front panel 7 3/4 x 6 3/4" aluminum—Blan the Radio Man.
- 1—Chassis 12 3/4 x 7 5/8" aluminum No. 14 gauge—Blan the Radio Man.

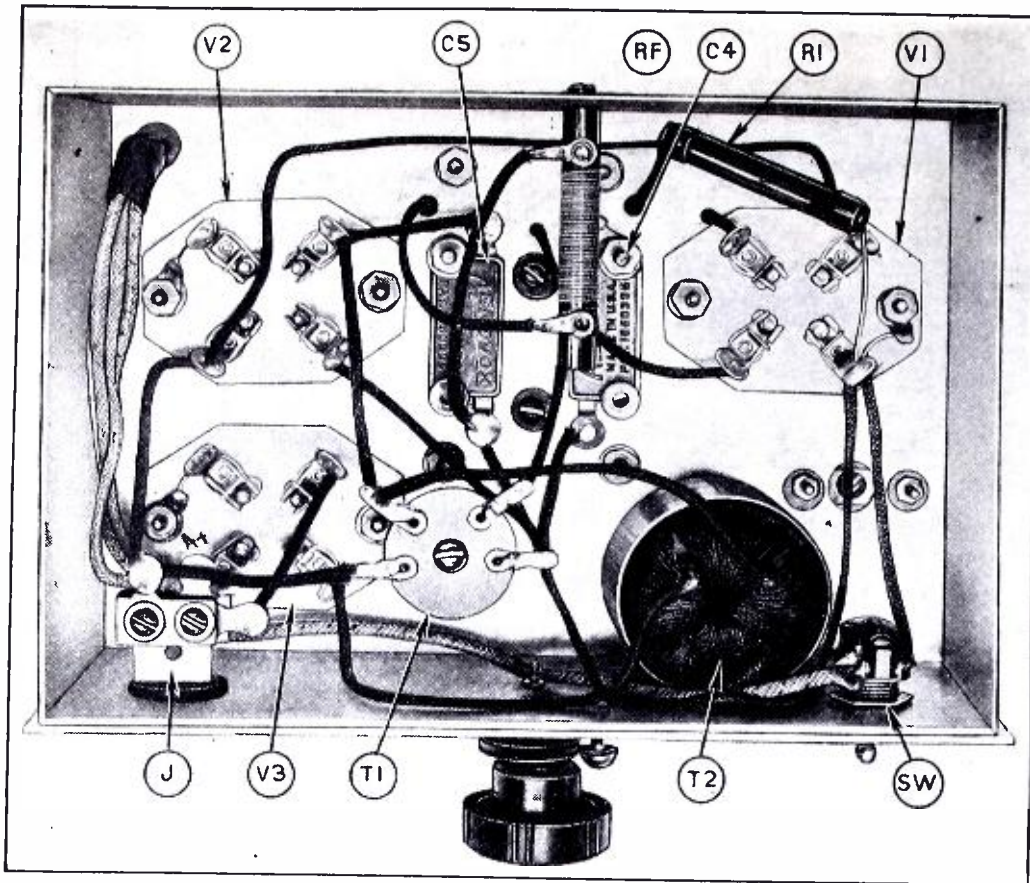

VIEW UNDERNEATH THE SIMPLE 5-METER RECEIVER

we get our super-regenerative action. Note also that the primary of T2 is connected in series with the plate circuit of V1, so that the audio signal is passed on through T2 to V3. An equivalent circuit diagram of the quenching circuit connections is shown in an additional sketch. The small fixed condenser C5 is used for the purpose of bypassing the quenching frequency and, at the same time, allowing the much lower frequency audio signal to pass through.

#### Constructing the Receiver

With the aid of the pictorial diagram and the photographs, no difficulty should be experienced in building the set. Drill and bend the chassis as shown in the mechanical drawing. Then mount the sockets, V1, V2 and V3, the mica condenser C3, and the 3-plate tuning unit C2 on the top deck. The midget condenser used here is a Hammarlund, and in order to avoid body capacity effects, a 2-inch extension may be made with an insulating coupling, as shown. Since the rotor of the tuning condenser is not at ground

(Continued on page 45)

self. Referring to the diagram of the set, C1 is a small condenser inserted in series with the antenna and, when once adjusted, may be left alone. L1 is the secondary; L2 the tickler; and C2, a 3-plate midget, is the tuning unit. V1, of course, detects the original signal. Tube V2 generates the quenching frequency; V3 is an ordinary audio amplifier which connects to a pair of phones.

T1 is composed of coils L3 and L4, which, together with C4, generate the quenching frequency. An examination of this part of the circuit shows that L4 is the ordinary grid

coil and L3 a tickler in the quenching circuit. The plate of V2 connects to the primary of T2, then through the coil L3 to B plus. The primary of a.f.t. is shunted by a fixed condenser, C5. The plate of V1 connects through L2, the tickler, then to a small r.f. choke, then through the primary of T2, and finally through L3 to B plus. When V2 is oscillating at the quenching frequency, the voltage across L3 is alternating at the quenching frequency and is, by virtue of the circuit connections, connected in series with the plate circuit of V1; hence

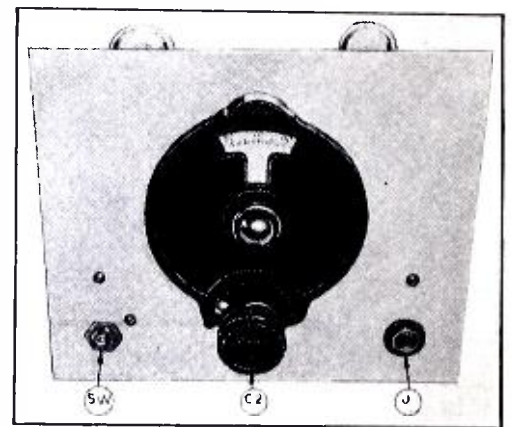

PANEL VIEW OF THE SET

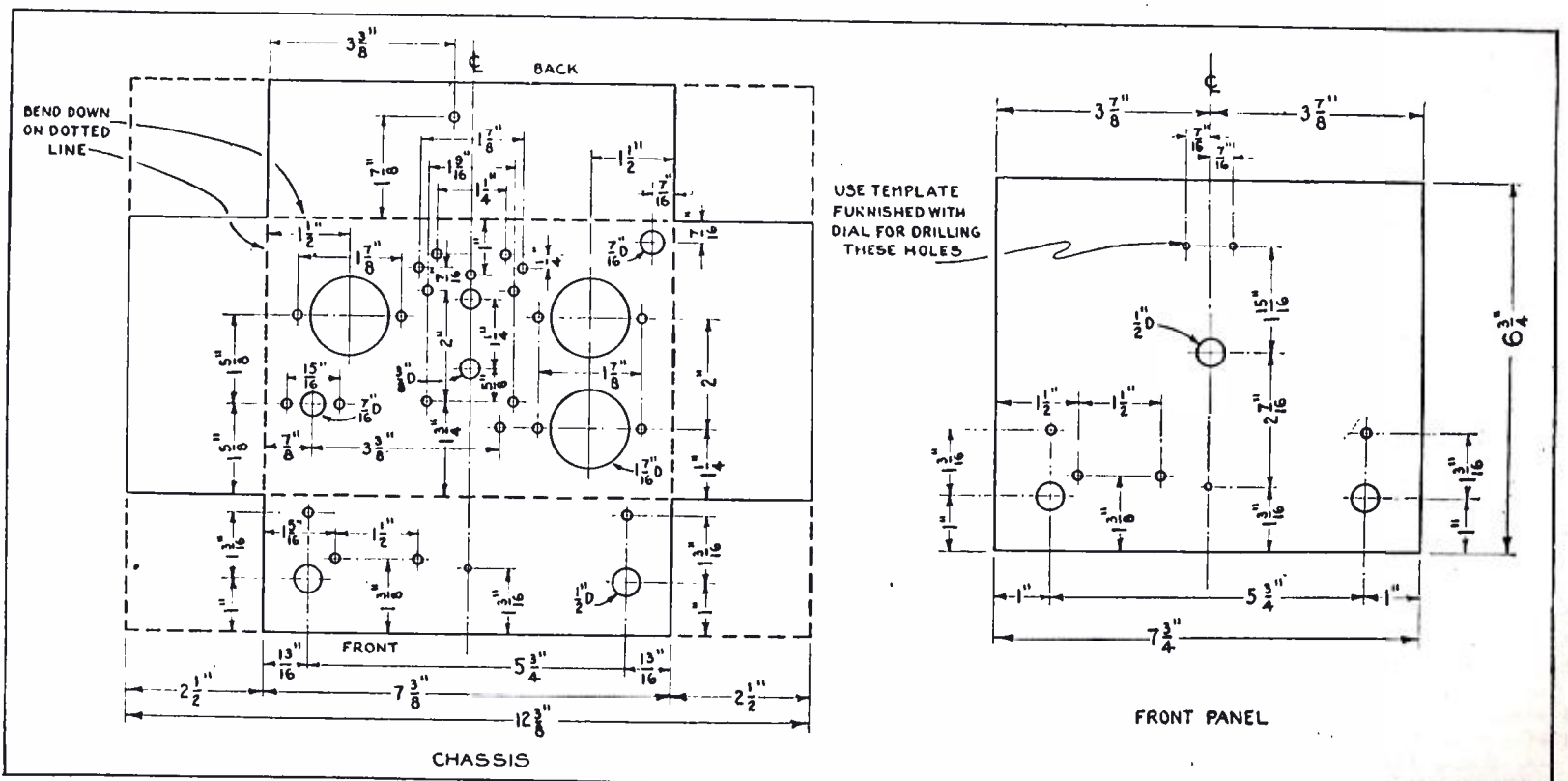

COMPLETE DRILLING LAYOUT OF THE PANEL AND CHASSIS OF THIS RECEIVER

# Not the "How" But the "Why" of Superheterodynes

**SUMMARY:** Countless articles have been written on the theory of operation of superheterodynes. These articles usually confuse the average reader simply because they do not state why things are done; they almost all tell

you how things are accomplished. It is the purpose of this article to state in perfectly understandable terms just why we need oscillators, intermediate frequencies, ticklers, etc., not how they work after we have them.

**M**OST of the confusion in radio construction work arises from the fact that the designer wants the greatest sensitivity for the least expenditure of parts, tubes, etc. This desire on the part of the experimenter is not due to traces of Scottish ancestry, but to a perfectly natural desire to get the most out of what is expended. It is this desire that led to the discovery of regeneration, superheterodyne action, reflexing and many other combinations, whose operation is excelled only by the impressiveness of their names.

## The Superheterodyne

Most readers are familiar with the action of the simple tuned circuit shown in Fig. 1. The signals from the antenna are tuned in by the condenser C1, amplified by the tube and again tuned in by condenser C2, which tunes the r.f. transformer labeled T2. Figure 1, therefore, represents a single stage amplifier. If additional amplification is desired, another tube may be connected to the secondary of T2; if not, then T2 may connect directly to either a crystal or a vacuum-tube detector. In this manner, as many stages of amplification as desired may be used—at least theoretically.

So far, all would be well were it not for the fact that the process of amplification shown is only good when the very long wavelengths are used—say in the neighborhood of 1,000 meters (300 kc.). As the wavelength goes down (frequency goes up), a few things begin to happen that are not desirable, but can't be helped. In the first place, instead of all of the signal going through the primary of T2 into the secondary, some of it goes back through the tube to the secondary of T1, and mixes with the signal coming in. The result, of course, is hash. How does it go through the tube? That's easy.

A condenser is composed of two metal plates placed close together. Such a condenser will not pass di-

By L. van der Mel

rect current, but will pass alternating current; furthermore, the higher the frequency, the greater the current through the condenser with a given, fixed voltage. Now, the plate and grid in the tube of Fig. 1 are really two plates of a condenser, so that the a.c. in the plate circuit goes through this condenser (sometimes erroneously called a *fictitious condenser*) and causes trouble. We can see, therefore, that if we are tuning in a high-frequency (low wavelength) signal, we cannot get as much gain from the set as we could on a lower-frequency signal, and there is a possibility of extreme distortion existing because of the mixing of the original signal and that part of the amplified signal that is fed back through the tube capacitance. Here is why we cannot get as much gain:

The amplified signal appears as a voltage drop across the primary of T2. This voltage is just like any alternating voltage—like one across

the secondary of ordinary filament transformer, for instance. Now, this voltage is, of course, greater than the signal voltage applied to the grid of the tube,—since the tube has amplified it—so that it causes current to flow through the tube capacitance, back to the grid circuit of the tube, as shown in Fig. 2. If this plate signal voltage becomes greater than the original signal voltage by a certain amount, the *feedback* becomes so excessive that the tube starts generating currents of its own—the tube starts to oscillate. How can the voltage become too great?

The plate signal voltage may become too great in three different ways: first, the tube may have a high *amplification factor*; second, the inductance of the primary of T2 (Fig. 1) may be high; and third, the frequency may be high. Let us discuss each of these factors separately.

(1) *Tube with a high amplification factor:* When a tube has a high amplification factor, the signal built up in the plate circuit is greater than it would be with a tube of low amplification factor. This means, of course, that a higher voltage is developed across the primary of T2, which means greater feedback—oscillation.

(2) *High primary inductance:* The voltage built up—generated—in a coil depends upon the rate of change of current, or *frequency*, and the size and shape of the coil. Therefore, if the frequency of the current is fixed by the frequency of the signal and strength of the current by the amplification factor of the tube, then the voltage developed across the primary of T2 will increase as the size of the coil increases.

(3) *High frequency signal:* To tune in a high-frequency signal we need a high-frequency circuit. This means that at the slightest provocation a voltage developed across the primary of T2 will generate a voltage in the grid circuit, and oscillation will result.

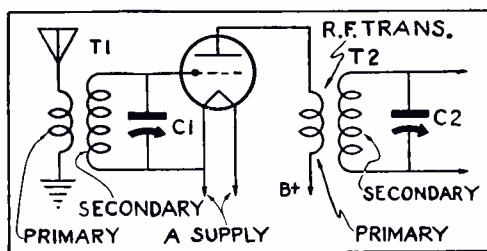

FIG. 1  
A SIMPLE TUNED CIRCUIT

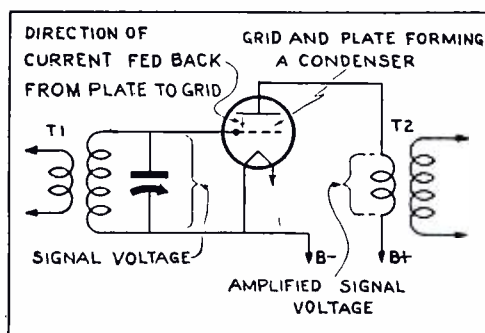

FIG. 2  
A SCHEMATIC ILLUSTRATING THE EFFECTS OF FEEDBACK FROM PLATE TO GRID

## The Intermediate-Frequency Amplifier

Of course, a low-amplification factor tube could be used in order to limit the generated plate circuit voltage. Such a procedure, however, means low gain, and should not be considered by any one who wants the most from his set. We could reduce the size of the primary of T2, and reduce the voltage that way; but here again, a small primary means a small voltage, and a small voltage means small gain. This system should not be used. The only remaining method, therefore, is to reduce the frequency to a value that will enable high gain with no oscillation. *This is exactly what the superheterodyne does.*

Up to this point it is clear that the best way to obtain high gain is to reduce the frequency of the signal to be heard to a low value, and amplify it at this new, low value. The amplifier that amplifies the low-frequency signal is called an *intermediate-frequency amplifier*. It is so named because it is placed between the antenna, or high-frequency stage, and the detector, or low-frequency stage.

### The Need for an Oscillator

Now that we have our intermediate-frequency (abbreviated i.f.) amplifier, the next problem is that of reducing the signal to a low value. This feat is neatly accomplished by the *oscillator*. It might seem paradoxical at first to deliberately take pains to eliminate oscillation, and then just as deliberately insert another oscillator in the circuit. It's not paradoxical, it's radio! The reduction of frequency has been covered in so many "how" articles that it will not be repeated here—this is a "why" article. We are concerned here with the fact that an oscillator is necessary to reduce the frequency of the incoming signal in order that it may be amplified effectively by the i.f. amplifier. The status of our receiver to date is block-diagrammed in Fig. 3.

One important point in connection with the oscillator-antenna circuit has not been emphasized enough in previous superhet articles. The point is that when the oscillator output mixes with the signal, the result is not a difference in frequency between the two—the difference in frequency is only obtained after the mixture is rectified, or detected. Hence the necessity for a first detector. Let us analyze this condition a little more.

The signal direct from a broadcasting station is a mixture of the steady carrier with the music or voice superimposed. If we want to hear the music, it is necessary to detect the wave with the ordinary crystal or vacuum-tube detector. The net result of this detection is to pull out the audio part—which we want to hear—from the entire mixture. Now, the grid of the first detector

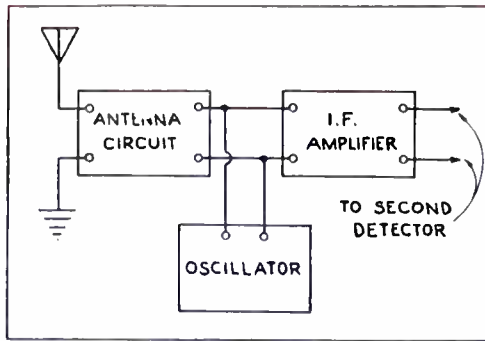

FIG. 3—BLOCK DIAGRAM OF A SUPER  
This diagram illustrates points of connection of the parts of the super.

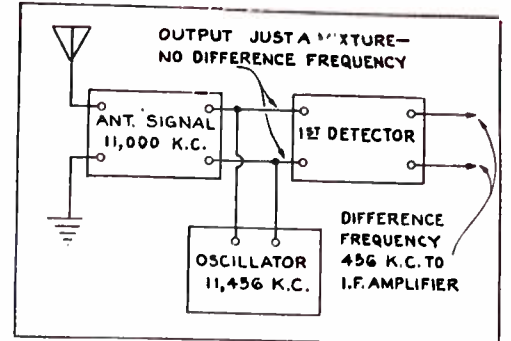

FIG. 4—ANOTHER BLOCK DIAGRAM  
This diagram illustrates just where the difference frequency is obtained.

tube in a super has both the oscillator and the signal voltages impressed upon it. In order to get the i.f. from the combination, it is absolutely necessary to detect the combination with a first detector, exactly as in any ordinary tuned-radio-frequency receiver. There is no difference frequency measurable unless detection takes place. This point is illustrated in Fig. 4.

The frequency of the oscillator is important simply because it determines the difference, or i.f., frequency. This difference frequency may be obtained in either of two ways: first, by having the frequency of the oscillator greater than the signal frequency by an amount equal to the i.f.; or second, by having the frequency of the oscillator lower than the signal frequency by an amount equal to the i.f. Either method works as well as the other, although the higher-frequency setting of the oscillator is almost universally used. The reason for this involves a rather complicated discussion of harmonics, image frequencies, etc., and will not be discussed here.

Our super now consists of an antenna circuit, an oscillator circuit and an i.f. amplifier which connects to a second detector in order to remove the audio which we want to hear. Of course, it is possible to install an r.f. amplifier ahead of the first detector in order to get amplification at r.f., before it is mixed with the oscillator. In this case, then, we will have one tuning condenser for the r.f. stage, one for the first detector, and another for the oscillator. The i.f. amplifier does not have any variable tuning condensers

for the simple reason that it works at a fixed frequency, and when once adjusted, stays constant. This represents one of the most distinctive advantages of the superheterodyne: it is possible to get many more stages of amplification before actual audio detection than in a tuned r.f. amplifier, not only on account of the lower frequency involved, but because of the obvious fact that no tuning condensers are required in the i.f. amplifier. In a receiver of the tuned r.f. type, a tuning condenser is needed for each stage. In a four-stage amplifier, four tuning condensers are necessary. In a super with the same number of tubes, only two tuning condensers are needed: one for the first detector and one for the oscillator. Thus, the super would have two stages of i.f. A block diagram of a complete superheterodyne using one stage of r.f., up to and including the second detector, is shown in Fig. 5. The function of each separate unit is shown on the diagram.

In the next installment, a description of the "why" of regeneration will be given.

While it is emphasized in this article that oscillation must be eliminated before successful operation of a superheterodyne can be obtained, it might be well to point out that, paradoxically, certain forms of oscillation are absolutely essential to the successful operation of regenerative receivers.

It might be well to further qualify the above statement by showing that unintentional, or parasitic, oscillations are undesirable; but oscillations that can be readily controlled are essential.

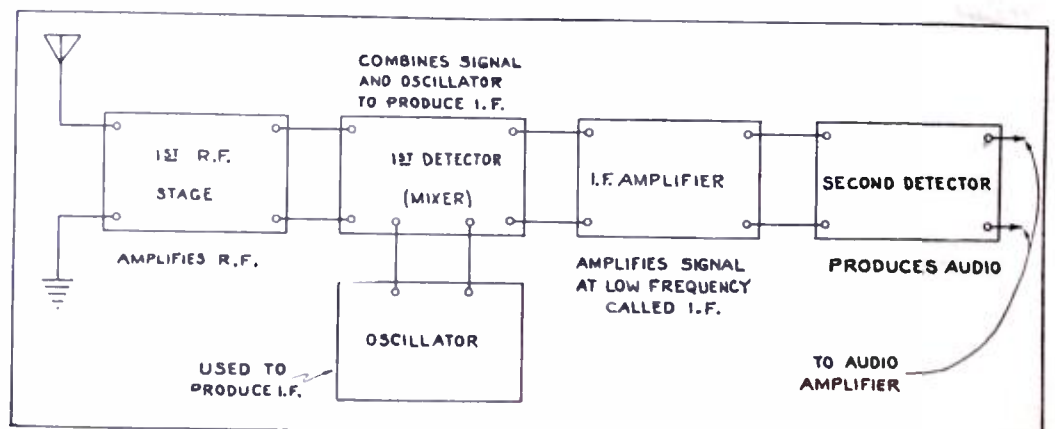

FIG. 5—BLOCK DIAGRAM OF A COMPLETE SUPERHETERODYNE RECEIVER  
The purpose of this diagram is to illustrate the function of each of the units used in a superheterodyne.

## The Maligned Modulator

(Continued from page 20)

### Modulator Couplings

Calmly assuming that the audio amplifier is O.K., we arrive at the final audio tube, which is normally called the modulator. The output of this audio stage is fed into the r.f. system for the purpose of modulating the r.f. carrier, and far too often this is done via a coupling device that is O. K.—in part. A common oversight is to use separate filament supplies for the final audio tube (modulator) and the modulated r.f. tube (modulatee?) without providing a low-impedance audio path between these two filament sources. Bypasses will patch this up if they have a capacity of 4 or 6 "mikes" each, but the really correct cure is one filament supply of ample size.

Again, where a Class A amplifier is coupled to an r.f. plate circuit through a resistance-capacity combination, one commonly finds the resistance bypassed with as little as 1 mf.—which quite effectively spoils low-note modulation. The plate supply for such a modulator system is usually through an iron-cored choke, and in numerous cases this has been found to have either insufficient inductance to operate well at low notes or to have such high distributed capacity as to let high notes escape. If one *must* use cheap chokes, at least use them with 2 or 3 times the current rating that appears to be necessary, and put several in series.

Class B amplifier stages (used as modulators) occasionally produce a curious effect: good audio at medium levels, fair audio at low levels, and terrible audio at high levels. In these cases one had better suspect two things at once—r.f. is sneaking into the audio system and damaging the low-level performance, or plate-supply surges are disturbing a buffer stage at high levels. In curing the first, consider the audio system as if it were a broadcast receiver in a broadcast station, and shield and filter as this suggests. As to the plate-supply surges, check up by temporarily using separate buffer plate supplies, or else what is nearly equivalent—feed the buffers through an *added* filter of about 100 H.—real henries—and 4 mikes.

### Reciprocity

Since the audio system is falsely accused for every crime of the sta-

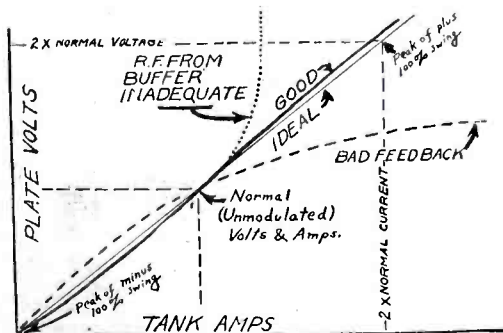

THE STRAIGHTER THE BETTER

# Win the Denton Trophy with an Acratone

## ACRATONE TWO TUBE KITS

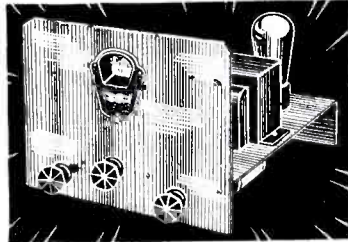

Models 15A, 10A, and 45A

### THE ARGONAUT KIT Model 15A

Uses 2 type 230 tubes. The first as a regenerative detector and the second as an audio tube. This receiver only requires two 1½ volt dry cells and a single 45 volt "B" battery.

Kit less coils and tubes.....\$5.65  
Set of batteries for above.....1.28  
Set of four coils, 15 to 200 meters.....1.29  
2 Raytheon 4 pillar tubes, 230.....1.37

### THE AIR ROVER KIT Model 10A

Similar to above but especially sensitive. Uses 1-232 and 1-233 tubes.

Kit less coils and tubes.....\$5.95  
Set of four coils, 15 to 200 meters.....1.29  
Set of batteries.....2.16  
Set of Raytheon 4 pillar tubes (1-232, 1-233).....2.12

### THE VOYAGER KIT Model 45A

Similar to above but A.C. operated. Uses 1-57 detector and 1-59 power pentode.

Kit less coils and tubes.....\$5.95  
Set of four coils, 15 to 200 meters.....1.29  
A.C. Power supply Cat. No. 739 (less 280 tube) 4.95  
Set of Raytheon 4 pillar tubes (1-57, 1-59, 1-280) 2.52  
**NOTE: Add \$3.00 for any of the above receivers if desired wired and tested.**

## THE ACRATONE DISCOVERER KIT

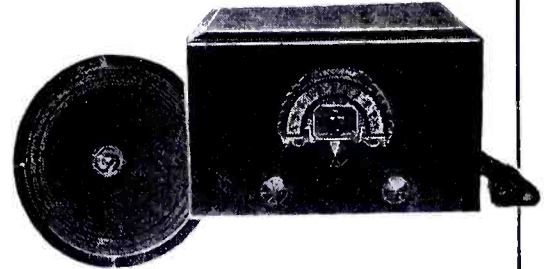

Model 20A

### A Real Distance Getter

A 5-tube A.C. operated short wave receiver

The Discoverer is a 5-tube T.R.F. receiver having one stage of T.R.F. using a 58 tube, two stages of audio, the first using a 56 tube and the second a 59 power output pentode and a rectifier stage using a 280 tube. The receiver is equipped with a self-contained power supply for 110 to 125 volts A.C. 50 to 60 cycles. A phone Jack is provided for those who prefer phones. Provisions are made for the noiseless doublet type antenna. A set of eight space wound coils are used, four for the R.F. stage and four for the detector. These coils cover from 15 to 200 meters.

### The Discoverer Kit

Complete with Cabinet, Parts, Full-Vision Dial, set of 8 coils (5 to 200 meters), Power Supply and Instructions **\$25.95**

8½" Dynamic Speaker—Specially Matched—Cord & Plug—Cat. No. 728 **\$2.80**

Set of 5 Raytheon Four-Pillar Tubes (2- 58's, 1- 56, 1- 59, 1- 80) **\$3.75**

## BUILD THE DENTON TRIFLEX

### COMPLETE KIT INCLUDES:

1 Set of 4 Special Plug-in Short Wave Coils covering bands from 10 to 200 meters, type No. 7814.....	\$1.85	1 Aeratest New-type Tube Shield, No. 7173.....	.20
1 Aeratest Triple Binding Post, No. 4106.....	.12	1 Frost 50,000 ohm Potentiometer, No. 6156.....	.45
1 Aeratest Twin Phone Tip Jack, No. 4969.....	.06	1 Flechtheim G.F. 100 By-pass Condenser No. 5275.....	.43
1 Four Prong Wafer Socket, No. 4062.....	.05	1 Aeratest .1 mfd., 200 volt Tubular Condenser, No. 5637.....	.08
1 Six Prong Wafer Socket, No. 6934.....	.06	2 Aeratest .001 mfd. Mica Condensers, type No. 6637.....	.14
1 Seven Prong Wafer Socket, No. 7524.....	.06	1 Aeratest .001 mfd. Mica Condenser, No. 6630.....	.08
2 Aeratest R.F. Chokes No. 6755.....	.20	1 Aeratest .00025 mfd. Mica Condenser, No. 6632.....	.10
1 Aeratest Midzer Variable Condenser .000025 mfd. No. 5256.....	.45	1 Aeratest 350 ohm, ½ watt Resistor, No. 5860.....	.08
1 Aeratest Variable Tuning Condenser, .00015 mfd. No. 6854.....	.95	1 Aeratest 3 megohm, ½ watt Resistor, No. 5860.....	.08
1 Four Conductor Battery Cable, No. 7184.....	.15		
1 Aeratest Shielded Metal Chassis & Front Panel, No. 7850.....	1.50		
1 Aeratest Dial & Drive Unit, No. 7779.....	.25		
1 Aeratest Escutcheon Plate, No. 4043.....	.15		
1 Aeratest Screen Grid Clip, No. 4173.....	.02		
3 Black Knobs, No. 3565.....	.30		
		1 Raytheon 6 F 7 Tube.....	\$1.32
		<b>TOTAL—</b>	<b>\$7.81</b>
		Net Price of Above Parts if Purchased in one Kit	
			\$6.95
			\$1.32

All our branches carry a complete line of short wave sets and parts, replacement parts, broadcast receivers, tubes, public address equipment, meters and other radio supplies. Send for our complete 108-page FREE catalog.

## Federated Purchaser Inc.

25 Park Place, New York, N. Y.

ATLANTA Ga. 631 Spring St. N. W.	Philadelphia, Pa. 2909 N. Broad St.	Jamaica, L. I., N. Y. 92-26 Merrick Road	BRONX, N. Y. 534 E. Fordham Rd.	NEWARK, N. J. 273 Central Ave.	Pittsburgh, Pa. 343 Blvd. of the Allies	CHICAGO, ILL. 1331 S. Michi- gan Av.
--	---	--	---------------------------------------	--------------------------------------	---	--

# Complete Kit of Parts for the "CONVERTIBLE 5"

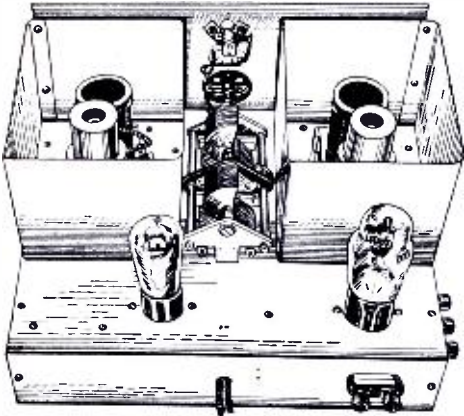

## NOW! PERFECTED LOUD SPEAKER RECEPTION FROM FOREIGN STATIONS

London, Paris, Rome, Madrid, Sydney, Buenos Aires—the world at your finger tips with the new short wave "Convertible 5". Clear, undistorted reception from your loud speaker, with sufficient volume to compare with local broadcasts. Covers all short wave channels between 13 and 200 meters.

You radio fans will enjoy constructing this new, modern kit. Simple, easy wiring and construction. Tested circuit employs the newest 1933 pentode tubes, full A.C. operation, freedom from body detuning effects, and dynamic loud speaker reception from European, Asiatic and Australian stations.

Send 35c for easy to follow wiring diagram and complete list of individual parts and price. We carry all parts for the Convertible "5".

### It's Free

Send for Your Copy  
of this New Big  
RADIO CATALOG  
of  
Sensational Bargains



Here is the latest, greatest catalog ever issued by WHOLESALE RADIO SERVICE CO. More than 10,000 Bargains are listed! Every latest development of the foremost manufacturers is here! SETS, TUBES, SPEAKERS, REPLACEMENT PARTS, KITS, etc.—all at LOWEST WHOLESALE PRICES!

### SHORT WAVE APPARATUS

A most complete selection of short wave sets, converters, coils and equipment is displayed here. Nationally known makes such as NATIONAL, HAMMARLUND and LAFAYETTE featured prominently.

### PUBLIC ADDRESS

comes in for a big share of attention in this catalog. Amplifiers, Amplifier Kits, Complete Systems, Portable Systems and all kinds of equipment are listed at prices which are truly amazing.

### SPECIAL FEATURES

covering Lafayette Receivers, Trustest Parts, Miniature A.C.—D.C. Portable Sets, Testing Equipment are a few of the special features in this most complete Radio Catalog of the entire industry! BUY FROM WHOLESALE RADIO SERVICE CO. at lowest wholesale prices—where your satisfaction is guaranteed and where the promise of prompt service is performed!

**WHOLESALE RADIO SERVICE CO.**  
100 SIXTH AVE.  
CORNER GRAND ST. (ONE BLOCK ABOVE CANAL) NEW YORK, N.Y.

- I enclose 35c for wiring diagram and price list of individual parts.  
 Please Rush your Brand New Catalog.

Name .....

Address .....

City ..... State .....

tion and the ether, it is fair to turn about and demand that the r.f. system prove its innocence. This means that the r.f. system must show ability to accept modulation and to reproduce it. This isn't as complex as it sounds—though unfortunately there has been widely published a curious and confusing definition of Class C (tube to be modulated) operation. This tube almost always operated with a plate tank-circuit which is tuned. An r.f. meter can be connected across a turn or two of this tuned coil and proper operation has been obtained when the current shown by that meter varies in proportion to the plate voltage. If the normal plate voltage is 250 and the normal tank-meter reading 2.5 amperes, then the meter should read 1.1 amperes at 110 volts and 5 amperes at 500 volts. Try it point by point and see.

If the meter readings do not go up and down in direct proportion to the plate voltage—even the most moral modulator will never get perfect speech out of the critter. Sometimes the proportionality is O.K. at points below the normal voltage, but not above—meaning that we can modulate down O.K., but not up without distortion. Any one of a lot of things may be wrong. The final filter condenser must be at least 4 mikes—6 is better—8 for a Class B system. The r.f. feed to the grid of the modulated r.f. tube may be wrong—generally too much. The neutralization may be wrong. The bias of the modulated tube may be incorrect or variable—better get it partly from a grid leak and avoid grief.

Oh, any one of a whole lot of things may be wrong; and mostly they can be located right at the transmitter, and mostly they are anywhere except in the modulator.

And that's our story—and we give you fair leave to go back to your apparatus with new confidence and self-esteem. And if any self-appointed long-distance listening wizard starts to edit and revise your modulator—just ask him to go back to his musty old Middle Ages where they used to believe in him.

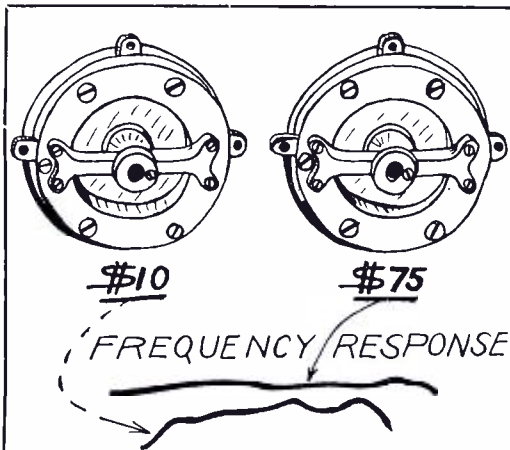

RESPONSE VS. PRICE

The quality of a microphone is almost a direct function of its price.

## SHORT WAVE EXCHANGE

Have you some apparatus to sell or swap, or some special service to offer to other short-wave fans? Take advantage of the low rates of this department to reach other "hams". Only 5 cents per word for amateurs, 8 cents per word for manufacturers or dealers. Name, initial and address each count as one word. Not less than 10 words accepted. Cash, money order or U. S. postage stamps must accompany all advertisements. Please write clearly.

SHORT WAVE RECEIVERS at bargain prices. Write W. A. Kiesow, Morgan, Minn.

PLUG IN COILS. Set of four wound on bakelite. Four-prong forms. 15-210 meters. \$.50. Noel, 809 Alder, Scranton, Pa.

HAM SUPPLIES bought sold. Ennis, Route One, Johnstown, Pa., W8GPA.

QSL CARDS, NEAT ATTRACTIVE, Reasonably priced, samples free. Miller, Printer, Ambler, Pa.

THE ANSWER FACTORY has unsnarled many puzzles of amateur and commercial operators. Prompt quotations, reasonable prices. Robert S. Kruse, RFD No. 2, Guilford, Connecticut.

BRUNO condenser mike kit, brand new, \$1.00. 20 power brass draw telescope, spots .22 holes at 200 yards, used but good condition. \$1.50. Special Jensen 8" permanent magnet dynamic, for P.P. 38's, no baffle, new, \$3.00. A. Bachner, 3970—48th Street, Long Island City, N. Y.

## Question and Answer Service

**B**EGINNING with the next number, there will be a regular monthly question and answer department in SHORT WAVE RADIO. Matters of general interest to short-wave fans will be discussed in this section in brief, understandable language.

Readers desiring personal replies to their questions are requested to observe the following simple rules: (1) If your question is of a straight technical nature and does not involve the preparation of diagrams by us, merely enclose a stamped and addressed envelope; there is no charge for the service. (2) If you want diagrams of sets using not more than five tubes, please enclose twenty-five cents (U. S. stamps are acceptable); for larger diagrams, fifty cents. We are forced to charge these modest fees because the drawing of diagrams to fit individual collections of parts and equipment takes considerable time, and often entails actual engineering design effort.



45 Vesey Street, New York City  
New York Headquarters for Transmitting Apparatus

The Radio Amateur has found it convenient to shop at LEEDS. Only quality merchandise at wholesale prices.

We have a complete line of the following:

- National
- General Radio
- Hammarlund
- Weston
- Jewell
- Cardwell
- Flechtheim
- Morrill
- Universal

and many others

We do not publish a catalog; quotations on all short wave equipment furnished by return mail.

### UNIVERSAL MICROPHONES and stands at lowest prices

Model W lapel single button.....	\$1.75
Model X double button.....	5.88
Model X single button.....	4.41
Model BB .....	14.70
Model X desk stand.....	2.05
Special floor stand nickel plated..	5.88
Suspension springs, 8 for.....	.25

All other Universal products reduced to above proportions

### Navy Type Telegraph Key

List \$3.60 Navy knob— $\frac{1}{8}$ " tungsten contacts. Special .....\$1.25 with regular knob..... 1.10



### "KEY KLIP" IS OUT!

Thousands of amateur radio items at the lowest prices, are contained in this immense 192-page FREE book, together with many

interesting articles by people well known in amateur radio circles.

Get your copy NOW

### AMERICAN SALES COMPANY

Wholesale Radio Distributors

44 W. 18th Street, - New York, N. Y.

The Oldest "HAM" Supply House  
Established 1919



### Subscribe? Sure!

Why not now? No reason at all. Then turn to page 48 for a real, man-sized coupon and an invitation to read the greatest short-wave magazine ever printed. Everything for the transmitting and receiving amateur is to be found. Don't guess—know!

### 5-Meter Receiver

(Continued from page 40)

potential, it is necessary to insulate it from the metal chassis. This is another reason why the coupling between the condenser and extension shafts must be of the insulating type. If these shafts were connected metallically together, then the rotor of the condenser would be placed at nearly ground potential because of hand capacity when tuning, and the stability of the receiver would be thrown off considerably. Underneath the chassis, condensers C5 and C4, resistor R1, transformers T1 and T2, the off-on switch and the phone jack are placed in position and wired as per either the pictorial or schematic diagram.

### Constructing the Coils

Coils L1 and L2 are seen to be mounted in mid-air, close to the tuning condenser. Each consists of  $3\frac{3}{4}$  turns of No. 14 solid enamel wire, wound on a  $\frac{1}{2}$ -inch dowel stick. The spacing between turns is equal to the diameter of the wire. The spacing between L1 and L2 is approximately  $\frac{3}{8}$  inch. It might be well to try varying the spacing and the number of turns on each coil slightly in order to secure best results. The ends of the coils act as the support for the coils. With the midget tuning condenser and L1 and L2 as specified, the beginning of the 5-meter band

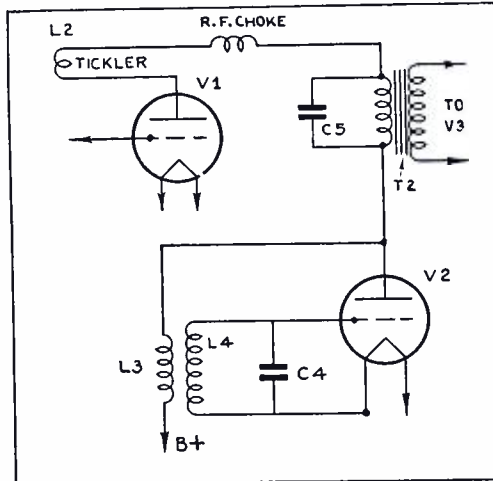

Circuit showing the series connection of the detector and quenching tubes, plate circuit.

should come out at about 10 on the dial.

Although the quenching coils L3 and L4 used in the receiver are commercial, they may be wound at home as follows: L4, 1,400 turns of No. 34 silk-covered wire, wound on a  $\frac{3}{8}$ " dowel between cardboard discs spaced  $\frac{1}{4}$  inch apart. L3 consists of 900 turns wound with the same size wire in exactly the same manner as L4. The choke r.f.c. may also be made by winding about 40 turns of No. 26 silk-covered wire on a bakelite rod  $\frac{1}{4}$ " in diameter. The winding length of this choke is approximately  $1\frac{3}{8}$ ".

(Continued on following page)

## Every RADIO WORKER Should Have the HAMMARLUND CATALOG

QUALITY of radio parts is the first essential of satisfactory performance.

That is why Hammarlund's more-than-thirty years of engineering experience means so much to radio builders who prefer performance to promises.

The new Hammarlund Catalog "33" describes condensers, coil forms, sockets, transformers, chokes, couplings, equalizers and shields for all types of radio work—transmitting or standard and low-wave reception. Mail coupon for your free copy.

### ISOLANTITE SOCKETS and COIL FORMS

Sockets have Isolantite base and perfect spring contact, for 4, 5 and 6 prongs. Isolantite Coil Forms for Short and Ultra Short Waves. No drilling. 4, 5 and 6 prongs.



### Improved MIDGET CONDENSERS

Ideal for short-wave and ultra short-wave tuning. Sturdy frame. Soldered brass plates. Smooth bearings. Four-point wiping rotor contact. Isolantite insulation. Not affected by temperature or humidity. Vibration-proof. Eleven stock sizes, 3 mmf. to 320 mmf. capacity.

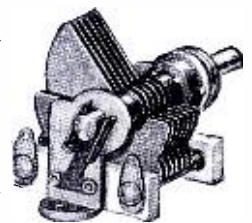

HAMMARLUND MANUFACTURING CO.  
424-438 W. 33rd St., New York, N. Y.

Check here for General Catalog "33."  Check here for folder on "Air-Tuned" I. F. Transformers.  Check here for booklet describing COMET "PRO" Short-Wave Superheterodyne.

Name .....

Address .....

SR-10

# LYNCH

Short Wave Antenna System  
will help you win  
the Clifford E. Denton Trophy

## American Sales Co.

44 West 15th Street, New York City  
July 20th, 1941

Lynch Manufacturing Company,  
11 Vesey Street, New York, N. Y.  
Attn: Mr. Arthur Denton

After considerable planning and pole sitting, we were successful in winning the Clifford E. Denton Trophy. The antenna system consisted of a 100 foot mast, a double loop antenna mounted 100 feet above the street level. We then used transparent blocks and transposed the leads all the way down to the second floor. In fact, the antenna is transposed right up to the receiver terminals in the show room.

In the past it has been impossible to receive many stations on the vacuum broadcast receivers we distribute due to the very high noise level created by machinery throughout the neighborhood. It was also practically impossible for us to demonstrate short wave reception until we installed your double antenna with transposed transmission lines. Without any exaggeration whatsoever, we found the noise level to drop 80% or more after the installation was made. We are now able to tune in broadcast stations on both the broadcast and short wave bands with practically no noise at any time.

Yours very truly,  
AMERICAN SALES COMPANY  
(Signed) L. Arno d

Complete Kit.....\$5.00  
AT ALL LYNCH Jobbers and Dealers

If your Jobber, Dealer or Serviceman cannot supply you, order direct from us. Sent post-paid, with instruction booklet, for \$5.00.

Free Descriptive Folder Upon Request

LYNCH MANUFACTURING CO., Inc.  
51 Vesey Street, New York, N. Y.

Makers of the Famous Metallized Resistors

**• MASTS •**

## VERTICAL ANTENNAS

are best for DX reception or transmission

We have complete stock of masts up to 100 feet made from clear, light spruce. We ship knockdown, with all holes drilled and with bolts, hardware and instructions.

We also carry complete line of parts for transmitting amateurs and we also manufacture complete line of radio equipment. We specialize in short wave receivers for 5 and 10 meter bands. Try our new Pentagrid Short Wave Four Tube Superhet at \$44.

You who live in Maine will do well to use our store as your base of supplies, as we carry only the best grades of apparatus.

COMMUNICATION LABORATORIES  
North New Portland, Maine

It should also be noted that the tubes used are all type 30's, and require two volts on their filaments. In all probability they will be used with two dry cells connected in series, giving a total of 3 volts. If so desired, a 15-ohm rheostat may be connected as shown at R2. If a fixed unit is desired, then R2 may be made about 5 or 6 ohms, which will maintain the filament potential at approximately 2 volts.

As stated at the beginning of this article, this receiver does not represent the ultimate in ultra-high-frequency receivers. Its main purpose is to acquaint the reader with 5-meter operation which, when developed a little more, promises to be one

of the most fruitful fields for the experimenter.

### Concluding Notes

Under normal conditions of operation, the super-regenerative receiver will give a loud rushing noise; but when tuned to a signal, this noise will disappear entirely and the station will come through clear and distinct. Antenna condenser C1 is adjusted to suit individual antenna systems and its correct position may easily be found by adjusting it until signal strength is at maximum. The fixed resistor R1 is merely used to place the grid of V1 at ground potential which stabilizes the grid circuit.

## Capt. Hall Identifies Foreign Stations

(Continued from page 12)

erated station located in Nassau, Bahama Islands.

RV59, Moscow, Russia, on 50.00 meters, is being heard again. Their scheduled time on the air is 2:00 to 5:00 p.m. E. S. T. The best reception is around 4:00 p.m. Eastern Standard Time. The technician of KGU, Honolulu, informs us there are no short-wave broadcasting stations in Hawaii. A commercial station used for telephony does occasionally transmit musical programs.

CTBAQ, Madeira, which operated on 26.83 meters has left the air according to information received.

An English correspondent informs us that there is a station in Russyelede, Belgium, reported on 29.5 meters.

Mr. Bass reports YV3BC, Caracas, Venezuela, on 48.95 meters, broadcasting until 12 p.m. Daylight Saving Time.

Pulling in stations is not such an arduous job, but "pulling" verifications of reception away from some of those foreign stations—that is where the work comes in.

Many fans have written us and asked what would be considered a diplomatic way for a beginner to go about this thing in the proper way. Here are a few hints, not only for the beginner, but also for the grey-

beard, who has become weary waiting an answer from a foreign station. But let me say right here that the foreign stations are not the only broadcasting stations that ignore letters addressed to them. I have written W8XK, Pittsburgh, Pa., several times, and am still waiting for an answer and they are only several hours away from our own back-door. So there!

Let us take this important item step by step. First, the tuner hears a program and writes down everything he hears. If several different musical selections are played, one right after the other, he should, if he is a wise tuner, make a note of this. Some stations have identifying signals, and the ones that have none generally give their call letters. Some stations announce at regular intervals, while others announce at the beginning and close of their broadcast. The language used will give the average tuner a very good idea of what station he is listening to.

When requesting verifications, describe the program briefly—not at length. Well, more next month.

## The Denton Trophy

(Continued from page 32)

N. Y., U. S. A., accompanied by a self-addressed stamped envelope or container, together with sufficient postage or international reply coupons to cover return by registered mail. Judges will not be responsible for any loss of verifications. All letters and cards of verifications, together with envelopes or other wrappers, should be presented. Stamps should not be removed or post-cards defaced. The judges will do everything possible to see that all verifications are properly returned to the contestants.

All prizes will be awarded with the stipulation that they may be displayed for one month after the award is made in any appropriate place or places that the judges may select.

## The "EAGLE" a new sensational 3 tube S.W. Receiver

The only popular priced set having the band spreading feature

**\$11.95**

### CHECK THESE FEATURES!!

- SCREEN GRID 2:2 R.F.**—and screen grid detector offering highest possible gain and most efficient regeneration.
- PENTODE POWER AUDIO**—231 gives more audio gain than obtained from two ordinary transformer coupled stages. Will operate speaker on most stations.
- TANK CONDENSER**—is operated from the front of panel and eliminates the objectionable necessity of lifting the cover. Speedy range changes at your finger tips. The ADDITIONAL condenser employed here gives much finer tuning than is possible with the ordinary large condenser.
- BAND SPREADING CONDENSER**—very small capacity permits widest possible calibration spread over a multitude of ranges. This feature gives you really two receivers for the price of one.
- DIAL**—Latest design, real vernier control over any position of the frequency covered. Absolutely will not jump or slip—very rugged.
- REGENERATION CONTROL**—Employs condenser for stability, ruggedness and a live-like smoothness, not noise like resistances.
- POWER CABLE**—Eliminates possibility of wrong connections and insures absolute electrical contact.
- CABINET**—Size 4" x 7" x 9 1/2", metal, compact, hinged cover, crystallized finish. Completely shields the receiver. Also ideal for portable use.
- RANGE**—15 or 200 meters—4 plug-in coils are supplied with each receiver. The "EAGLE" completely wired and tested. Price.....\$11.95
- TUBES**—Set of 3 tubes.....\$3.00  
Economical to operate. Employs the new 2 volt tubes which can be operated from two dry cells on the filaments for extended periods of time.

GROSS RADIO, Inc.,

Shortwave Headquarters 51 Vesey St., Dept. R, New York City  
Tel. Barclay 7-0161



No code stations, amateur, aircraft, police, ship or commercial stations will be considered in the contest, unless the verification actually states that the program received by the contestant was of broadcast nature. Only one verification from each short-wave broadcast station will be allowed.

In cases such as English, Swiss or German stations, where the same station uses more than one transmitter, wavelength or set of call letters, the verification must state the individual wavelength and call letter of the transmitter from which the program was received.

In writing to the various short-wave stations for verifications, it is suggested that the listeners-in mention the fact that such verifications are to be used in the Denton Trophy Contest. The cooperation of various stations is being arranged for by the trophy committee.

While it is not absolutely essential, it will simplify the work of the Denton Trophy Committee if prospective contestants will signify their intention of competing in this contest by advising the Denton Trophy Committee, 23 Park Place, New York City, N. Y., attention Clifford E. Denton.

SHORT WAVE RADIO heartily endorses this contest, and suggests that as many of its readers as possible enter it. It promises to be a lot of fun.

## The Triflex

(Continued from page 9)

culty that may be experienced is with the three holes for the coil, and tube, and the cable connector. With a little care and patience, these holes may be drilled by means of a series of small holes drilled around the circumference of the holes desired.

Now, mount the antenna-ground binding post strip; the phone terminals; the 5-plate midget condenser, C1; the regeneration control, R1; the tube, coil, and battery sockets; the 1 mf. bypass condenser; the a.f. transformer; and the tuning condenser, C6. In wiring the receiver, it is best to wire the filament circuit first, then the grid circuits, and, finally, the plate circuits, leaving the incidental resistors and condensers as a final operation, as these units are so placed that their leads must be as short as possible.

If the receiver starts to "motor-boat," try reversing the leads to either the primary or the secondary of the a.f. transformer. Only reverse the leads to one of the windings, not both.

If the details given here are followed to the letter, the constructor should have no trouble in getting the set to work properly. Do not attempt to redesign the set yourself before first constructing it as per the data given here.

## The Ideal Beginner's Set »»»

## The Famous 12,500 MILE TWO TUBE RECEIVER

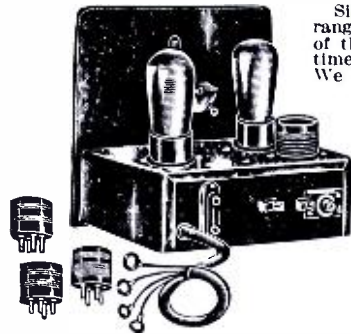

Simple to build—easy to operate—World-Wide reception range—and extremely inexpensive! We have sold thousands of these remarkable short wave kits and novices and "old-timers" alike have marveled at the amazing results obtained. We constantly receive letters from delighted purchasers reporting the reception of stations in all parts of the world and complimenting us on the excellent quality and performance of these sets! Getting foreign stations is an everyday occurrence!

**\$4.75**

These kits contain every necessary part to construct the entire receiver. The coils, which tune from 15 to 200 meters, are wound on polished bakelite forms. The attractive crystal finished metal chassis and panel comes with all holes necessary to mount the apparatus and this, together with our complete, detailed, clear instruction sheets, greatly simplifies construction.

Only by purchasing in tremendous quantities are we enabled to offer these neat, professional appearing sets at such a sensationally low price! And the parts are all first grade, too!

Get started in this most interesting and instructive phase of radio—Short Waves. Send your order in NOW!

### BATTERY MODEL

Uses two 230 tubes. Batteries required are two dry cells (or a 2-volt storage cell) and two 45 volt B Batteries. If you have a 6-volt storage battery you may use 201-A's. **\$4.75**  
**COMPLETE KIT . . .**

### AC MODEL

Uses two of the new type 56 or 27 tubes. Power is obtained from the AC Power Pack listed below (or any GOOD pack), or it may be run on a 2½ volt filament transformer and two 45 volt batteries. **\$4.95**  
**COMPLETE KIT . . .**

### AC POWER PACK

A compact power unit measuring only 3½x7x1½ high. Delivers A, B, and C voltage for up to a four tube receiver. Even one using a power tube! Can also be used for low-power transmitter. Provision for dynamic field supply. Uses one 280. Output: 250 Volts DC at 70 MA and 2½ Volts AC at 5 Amps. Complete KIT including standard metal chassis and full instructions. **\$5.45**

### ACCESSORIES

Neat metal cabinet with 11-1/2" lid. For either receiver **\$1.00**. Wiring and testing of either set or pack—**\$1.50**.

### TUBES

RCA licensed tubes, carefully tested and packed. Fully guaranteed. Safe delivery assured. 230 64c, 201-A, 29c, 27, 35c, 56, 54c, 280, 35c. All other types at lowest prices! 2½ volt filament transformer—95c. D-Lac. Model L, \$1.25. Burgess made Dry Cells, 24c. 45 volt heavy B Batteries, \$1.15. Light weight Lead plates, 2000 ohm, \$1.15. 4000 ohm, \$1.35. 4000 ohm super-sensitive, \$1.75.

### SATISFACTION GUARANTEED

Deposit required with all orders

• FB-7  
• SW-3  
• SW-58  
**National**  
HAMMARLUND  
COMET "PRO"

### ROYAL "OLYMPIC"

AT PRICES THAT WILL SAVE YOU MONEY!

WE ARE PIONEER

### SHORT WAVE SPECIALISTS

and can make immediate shipment of practically any receiving or transmitting equipment. What do you need?

Send for **FREE CIRCULAR**

**HARRISON RADIO CO.** DEPT. D-1 142 LIBERTY ST. NEW YORK CITY.

## The New and Improved

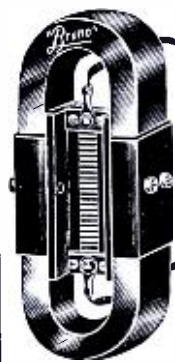

## VELOCITY MICROPHONE KIT

Excellent fidelity characteristics. Frequency response 30 to 14000 cycles per second. Not subject to variations with humidity and temperature. Substantially free from resonance peaks. Easy to assemble, not critical in adjustment.

DEALER'S PRICE **\$5.88** Net

### TRANSFORMERS TO MATCH

R. L. Ribbon to 200-300 ohm line **\$3.00**  
R. G. Ribbon to Grid **3** Each  
L. G. 200 ohm Line to Grid **3** Each  
Model R. V. 2-Velocity Microphone assembled with extra sensitive dural ribbon. Factory tested and guaranteed.

DEALER'S PRICE **\$11.76** Net

BRUNO LABORATORIES, 22 W. 22nd St., New York

## ALUMINUM BOXES AND CHASSIS



Pioneers in furnishing experimenters with special aluminum boxes, chassis and panels. Cut and made to any imaginable size. See back issues of any radio publication for last 10 years. We can supply any chassis described in this issue of *Short Wave Radio*. Prices? Lower than anyone else! **SATISFACTION GUARANTEED.**

### Radio Amateur's Handbook

200 pages of short wave hookups and information. Coil winding, antennas, rules, short cuts, hints, etc. Published Sept., 1932, by the American Radio Relay League at \$1.00. Now **45 cents.**

**BLAN, THE RADIO MAN, INC.**  
177 Greenwich Street New York, N. Y.

## KRUSE'S RADIOPHONE GUIDE

with contributions by

Boyd Phelps

R. R. Batcher

F. S. Dellenbaugh, Jr.

E. E. Griffin

Robert S. Kruse

## Tells How to

build grid-modulation systems, cure power-supply diseases, neutralize "mean" amplifiers, make class B behave, escape feed and antenna headaches, operate without class C bias battery, check modulation properly and more—

35 cents Postpaid

**Robert S. Kruse**

RFD No. 2, Guilford, Conn.

# why not SUBSCRIBE?

Why take the chance of missing the meaty "dope" that will be published in forthcoming issues of **SHORT WAVE RADIO**? Enter a subscription and have the magazines mailed direct to your home or office. Only \$2.50 per year for 12 issues in the United States and possessions; \$3.00 in Canada and foreign countries.

The best authors in the short-wave field will be regular contributors. Among these are Clifford E. Denton, Robert S. Kruse, Arthur H. Lynch, Capt. H. L. Hall, and Alfred A. Ghirardi. Keep up with short-wave radio by reading **SHORT WAVE RADIO!**

## SHORT WAVE RADIO

devoted to short-wave transmission and  
reception in all their phases

edited by  
**ROBERT HERTZBERG**  
and  
**LOUIS MARTIN**

STANDARD PUBLICATIONS, INC.  
1123 Broadway, New York, N. Y.

Enclosed is \$\_\_\_\_\_ for  
one year's subscription to **Short  
Wave Radio**. My full name  
and address are given at  
the right. (\$2.50 in U. S.  
and possessions; \$3.00  
in Canada and  
foreign countries.)

Here is a man-sized coupon that doesn't require a magnifying glass

Name \_\_\_\_\_

No. and Street \_\_\_\_\_

City \_\_\_\_\_

State \_\_\_\_\_

Call Letters  
(if licensed) \_\_\_\_\_



**Have you a friend who is  
also interested in short waves?**

*DO* him a good turn; show him this copy of **SHORT WAVE RADIO**. Mind you, we said "show," not "give". If you let it out of your sight you probably won't see it again! He will want to try Denton's tricky "Triflex," or cut out that valuable U. S. Navy time signal schedule, or study Capt. Hall's "dope" on the foreign broadcast stations.

If your friend holds on to your copy too tightly, just point significantly to the page opposite, and even offer him your pen so that he may fill out the coupon.

# **SHORT WAVE RADIO**

*devoted to short-wave transmission and reception in all their phases*



you must see the new

# RADIO PHYSICS COURSE

Including Short Waves, Television and Sound Pictures

(Second Enlarged and Revised Edition)

by ALFRED A. GHIRARDI

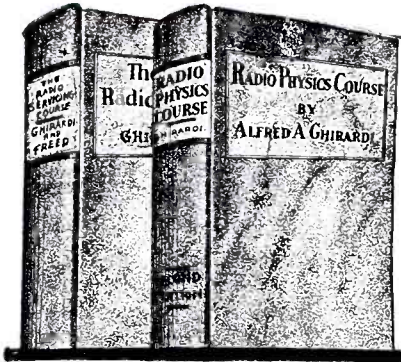

The Radio Physics Course  
contains 992 pages and  
over 500 illustrations.

Two Inches Thick!

Cloth Bound

Price

**\$3.50**

Postpaid anywhere in U. S. A.

Haven't you often felt that you would like to get hold of a book that would explain very carefully, step by step, and in a really interesting manner, everything there is to know about modern radio?

The new, revised second edition of the RADIO PHYSICS COURSE does just that—and more! It now contains, in addition to the most popular radio course ever written, a complete course in sound and electricity as applied to radio. Written in the same clear, simple style which has won the author great popularity as a writer for technical and radio magazines, and as a teacher of radio and electricity, this part of the new edition will be welcomed as a refreshing departure from the old electrical texts now in use. Free use of the modern electron theory has been made without going beyond the grasp of even the most non-technical student. You will be surprised at the ease and simplicity with which this modern tool of science, in the hands of so capable a writer as Mr. Ghirardi, has been utilized to clear up the many mysteries of electricity which have always troubled students. Electricity has not been treated as a "mysterious flow of something or other," but as a definite movement of vibrant electrons which have been skillfully made to create an absorbing interest in the subject.

Nothing is taken for granted, everything is explained simply, clearly and completely, with the aid of hundreds of carefully prepared diagrams and illustrations which the author has found invaluable in his practical experience in teaching this subject.

All chapters, including those on Vacuum Tubes, Superheterodynes, Electric Receivers, Short Waves, Television and the Talkies, have been brought right up to the minute, with complete descriptions of all the new developments brought out during the past year. We feel the chapter on Television to be the most sensible, complete and up-to-date explanation of this latest marvel of radio ever published. Even the new Cathode-ray television system is explained!

The Radio Servicing Course  
192 pages, 121 illustrations.

Cloth Bound

Price

**\$1.50**

Postpaid anywhere in U. S. A.

## THE RADIO SERVICING COURSE

by Alfred A. Ghirardi & Bertram M. Freed

This new book, by both the author of the famous "Radio Physics Course" and Mr. Bertram M. Freed, should be in the hands of every Service Man, Radio Student, Teacher and Technician, for it is the most comprehensive, up-to-date book on Radio Servicing ever written. It will show you how to make money by doing radio servicing scientifically, in a logical, rapid way with proper test equipment.

*Please do not send cash through the mail. Remit by post office  
money order or bank check to*

**Standard Publications, Inc., 1123 Broadway, New York, N.Y.**